

# Air-Driven, High Flow, High Pressure Liquid Pump

## Series ASL15-01

*Single-Acting, Single Piston Air Drive*

### **Technical Data: Liquid Side Specifications**

- Service: *Oil, Water or Water/Oil mixture and other fluids depending on material compatibility*
- Maximum Outlet Pressure: *2,300 psi (159 bar)*
- Air to Liquid Pressure Ratio: *1:16*
- Isolation Chamber (prevents process contamination of air section): *Optional*
- Volume Displacement Per Stroke: *3.62 in<sup>3</sup> (59.3 cm<sup>3</sup>)*
- Inlet Connection: *1" FNPT*
- Outlet Connection: *1/2" FNPT Female NPT*  
(Contact Parker Autoclave Engineers for Additional Options)

### **Technical Data: Air Side Specifications**

- Air Drive Pressure Range: *15-150 psi (1-10 bar)* \*See note
- Nominal air pressure required for 2,300 psi (159 bar) output pressure is 144 psi (9.9 bar)
- Inlet Port: *1/2" FNPT*
- Pilot Port: *1/8" FNPT (unregulated air)*
- Exhaust Port (muffler removed): *1/2" FNPT*
- Air Consumption @ 90 psi: *69 SCFM*
- Prelubricated at Factory

### **General Specifications**

- Maximum Operating Temperature: *0-140° F (-18° to 60° C)*
- Net Weight without Isolation Chamber: *38 lbs. (17.2 kg)*
- Net Weight with Isolation Chamber: *50 lbs. (22.7 kg)*
- Pressure Head: *15-5 PH Stainless Steel*
- Stainless steel plunger utilizing a proprietary multi-layer carbon based coating with diamond like carbon exterior layer - 3 times the hardness of stellite with a coefficient of friction equal to/less than PTFE
- Check Valve Glands: *316 Stainless Steel*
- Liquid Seal: *See Ordering Guide for Options*
- Air Drive Seals: *Buna N*

*Note: Maximum air drive pressure is limited by maximum output pressure.*



**Single-Acting, Single Piston Air Drive Pump**

Bottom Inlet Shown

MADE IN THE U.S.A.

## Ordering Guide:

For complete information on available pump options, contact Parker Autoclave Engineers.

Typical catalog number: **ASL15-01SNPV**

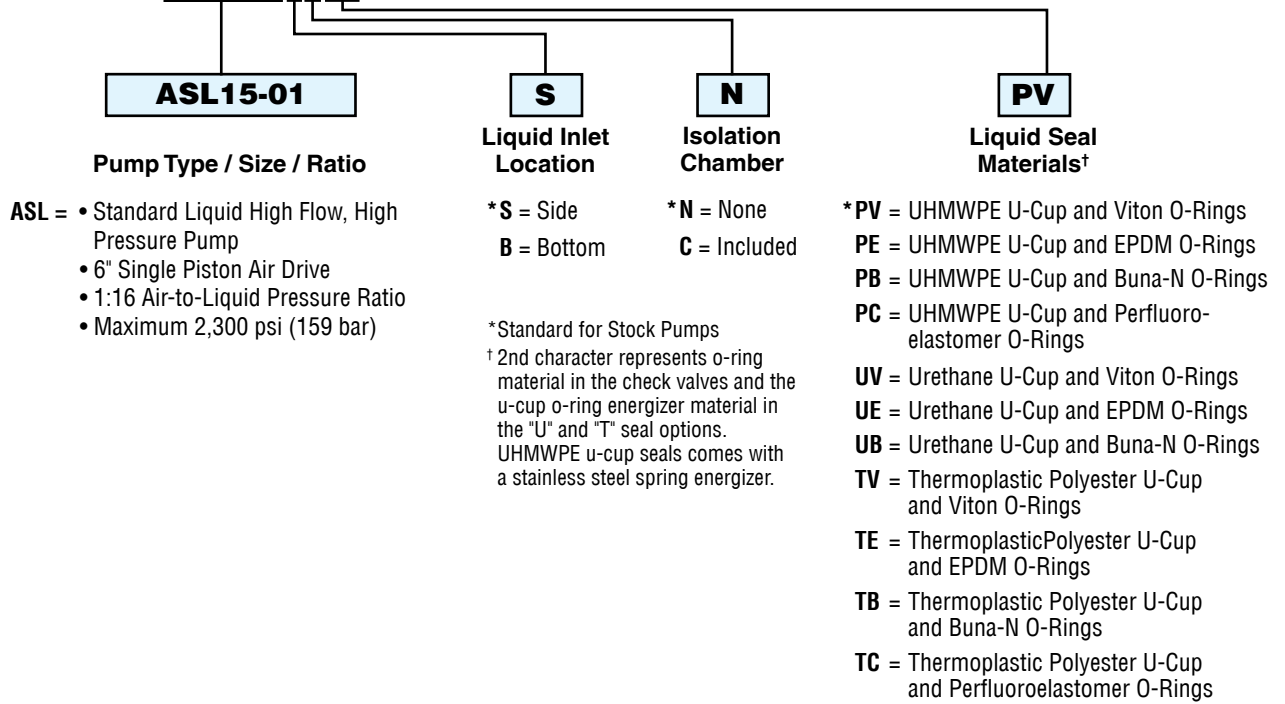

## Flow Rate vs. Outlet Pressure:

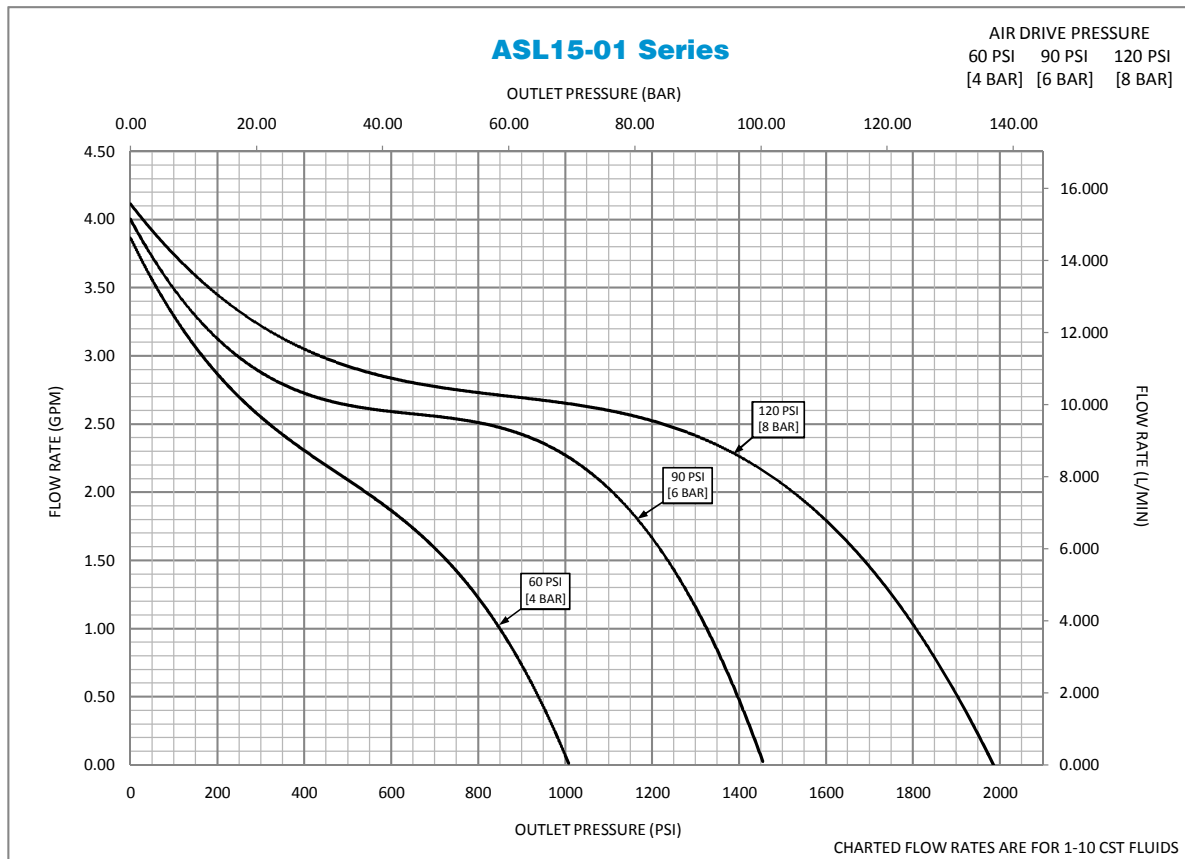

Actual flow rates will vary depending on air flow capacity, downstream flow restrictions, and fluid type.

## Dimensional Data:

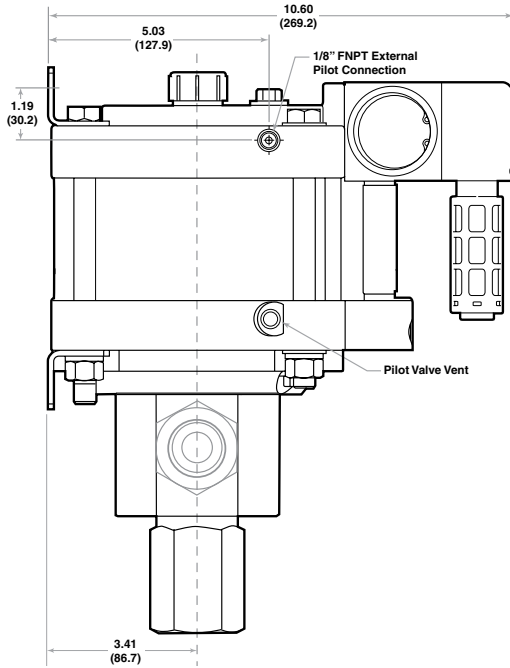

Left View

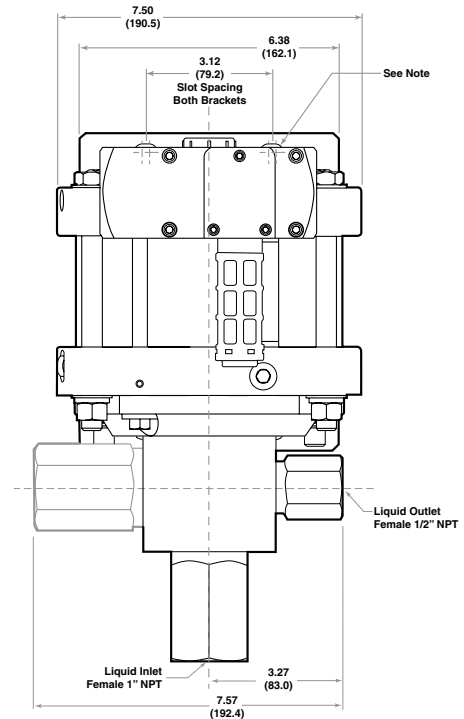

Front View

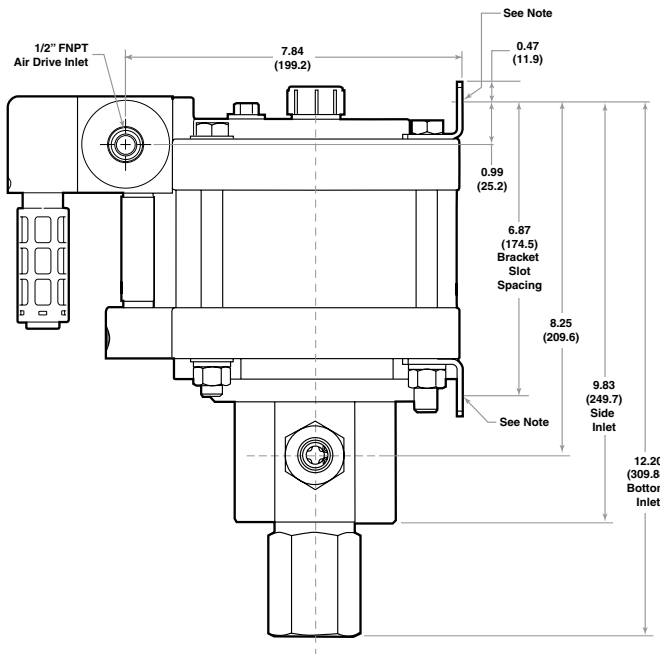

Right View

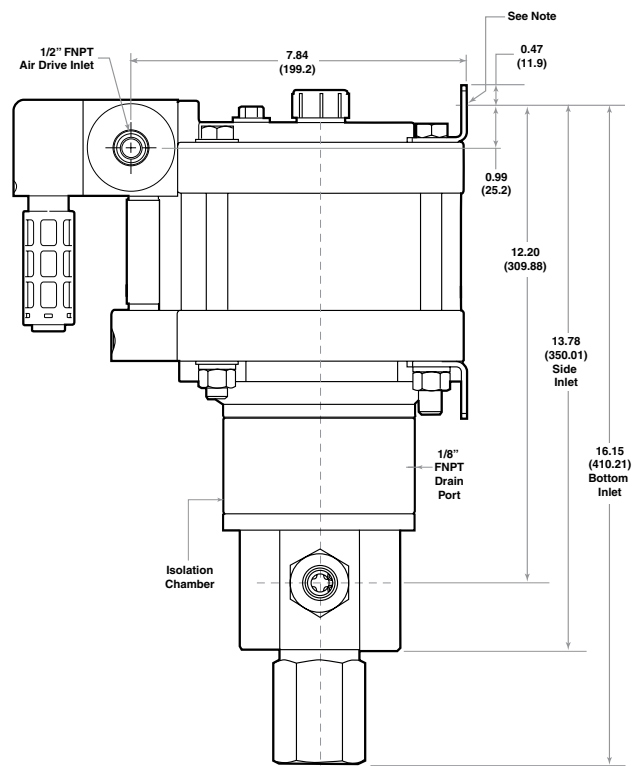

Right View with Optional Isolation Chamber

### Note:

Each Mounting Bracket includes (2) x 13/32" (10.32) Slots for 3/8" Bolts.  
 Bottom Inlet Pump Head and Side Inlet Pump Head are mutually exclusive.  
 All dimensions are for reference only and are subject to change without notice.  
 Primary Dimensions: Inches  
 Secondary Dimensions: (Millimeters)

## Accessories Available:

- Air Control Packages
- Pneumatic Pilot switches and Solenoid Valves
- Stroke Counter
- Relief Valve / Safety Heads
- Complete line of High Pressure Components - Valves, Fittings & Tubing
- Spare Parts
- Service



Typical Air Control Package



For complete information on available high pressure accessories, please contact Parker Autoclave Engineers.

#### WARNING

**FAILURE, IMPROPER SELECTION OR IMPROPER USE OF THE PRODUCTS AND/OR SYSTEMS DESCRIBED HEREIN OR RELATED ITEMS CAN CAUSE DEATH, PERSONAL INJURY AND PROPERTY DAMAGE.**

This document and other information from Parker Hannifin Corporation, its subsidiaries and authorized distributors provide product and/or system options for further investigation by users having technical expertise. It is important that you analyze all aspects of your application and review the information concerning the product or system in the current product catalog. Due to the variety of operating conditions and applications for these products or systems, the user, through its own analysis and testing, is solely responsible for making the final selection of the products and systems and assuring that all performance, safety and warning requirements of the application are met. The products described herein, including without limitation, product features, specifications, designs, availability and pricing, are subject to change by Parker Hannifin Corporation and its subsidiaries at any time without notice.

#### Offer of Sale

The items described in this document are available for sale by Parker Hannifin Corporation, its subsidiaries or its authorized distributors. Any sale contract entered by Parker will be governed by the provisions stated in Parker's standard terms and conditions of sale (copy available upon request).

© 2013 Parker Hannifin Corporation | Autoclave Engineers is a registered trademark of the Parker Hannifin Corporation

02-9249BE

January 2013



**Instrumentation Products Division**  
Autoclave Engineers Operation  
8325 Hessinger Drive  
Erie, Pennsylvania 16509-4679 USA  
PH: 814-860-5700 FAX: 814-860-5811  
www.autoclave.com

Parker Hannifin Manufacturing Ltd.  
**Instrumentation Products Division, Europe**  
Industrial Estate Whitmill  
Wexford, Republic of Ireland  
PH: 353 53 914 1566  
FAX: 353 53 914 1582

**Caution!** Do not mix or interchange parts or tubing with those of other manufacturers. Doing so is unsafe and will void warranty.

**ISO-9001 Certified**

**Air-Driven, High Flow, High Pressure Liquid Pump - Series ASL15-01**