

FLOMORE

Different By Design

1300 Series Injector

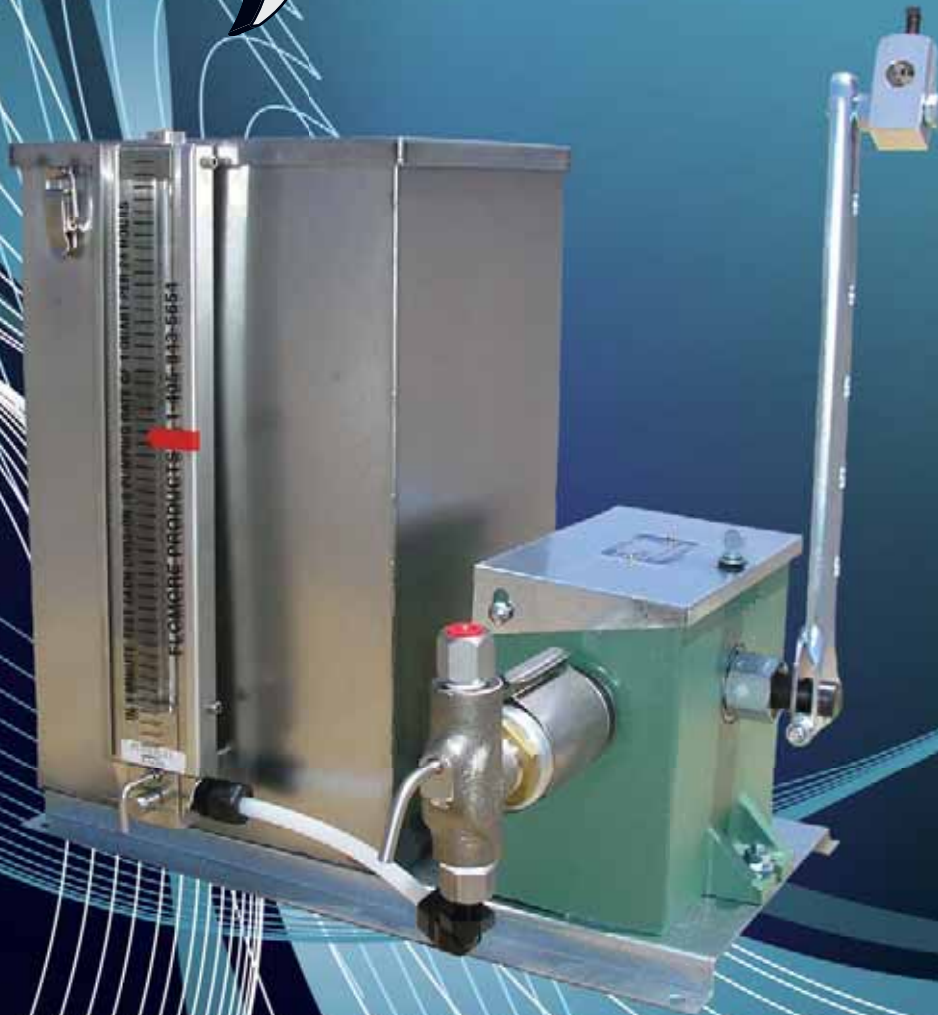

1300 Series Injector

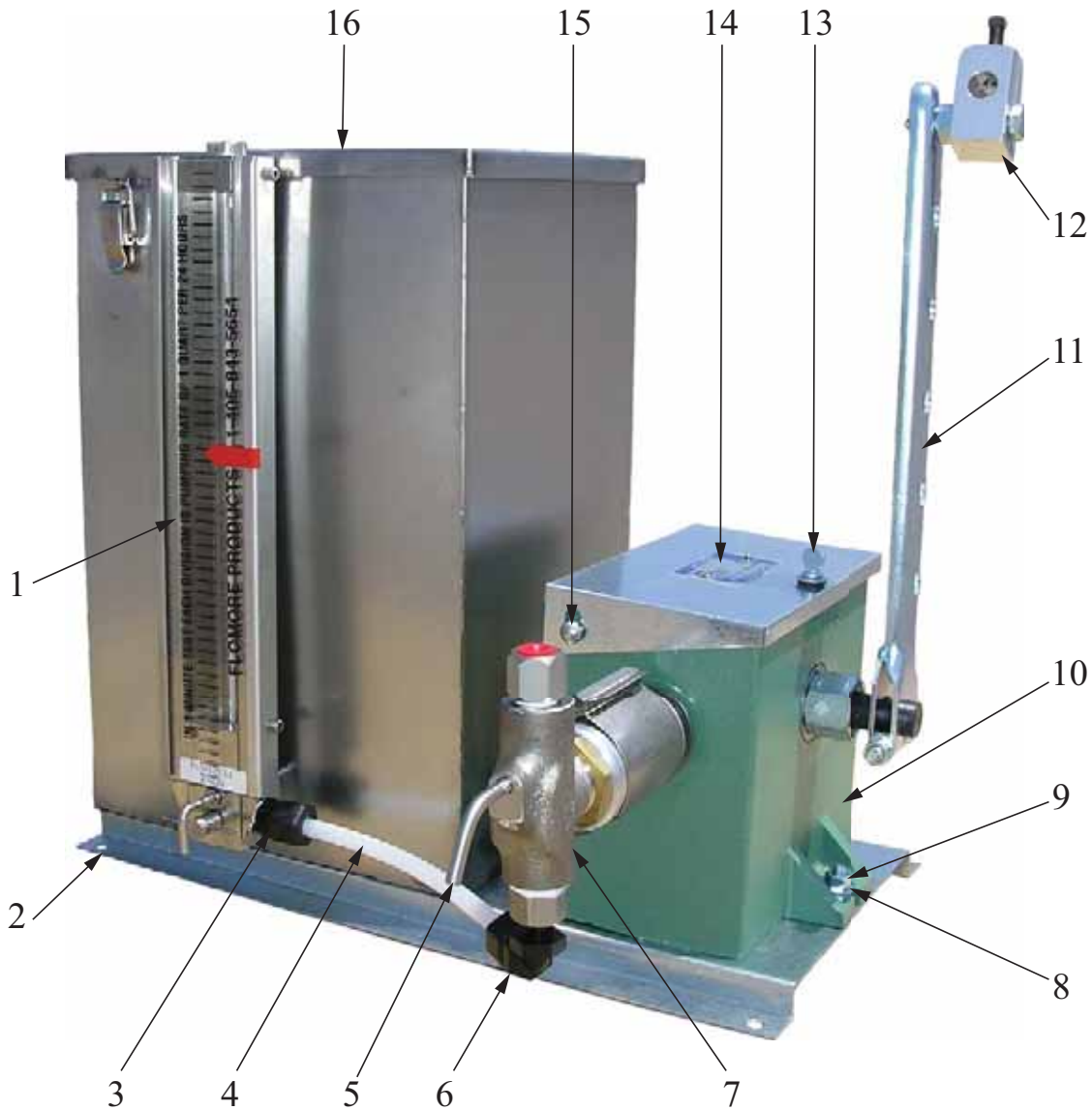

Parts List

Item #	Part #	Description
1	F-0871	Stainless Steel Tank Gauge Assembly
2	A-0535	Base Assembly
3	A-3118	Connector Compression Nut Assembly
4	A-3117	Suction Line
5	A-1497	Priming Valve
6	A-3116	Elbow Compression Nut Assembly
7	See Page 6	Head Assembly
8	A-0163	Bolt

Item #	Part #	Description
9	A-0164	Nut
10	B-0091	Box Assembly
11	B-0067	Lever Arm
12	A-0538	Connecting Knuckle Assembly
13	A-2577	Lid Thumb Screw
14	A-0960	Lid
15	A-0528	Cover Rivets
16	A-0664	Five (5) Gallon Reservoir Assembly

Installation and Operating Instructions

1. Install Item #5 priming valve (included with pump, but shipped loose in carton) on the pump head.
2. Connect the suction line to the pump head. If a reservoir is furnished with the pump, the suction line is already connected. Fill the reservoir and completely open the tank gauge valve.
3. Connect the discharge line (5/16" tubing will suffice). One A-0676 1/4" brass line check is provided. This valve should be installed as close to the point of injection as possible.

NOTE: The arrow on the check valve indicates the flow. The top connection of the pump head is the outlet and has a 1/4" female pipe thread connection.

4. Connect the lever arm to the power source as follows: (make sure the pumping unit cannot start automatically)
 - 3/8" OD rod or pipe (usually 10' to 12' is required for an oilfield walking beam pump). Attach an A-0701 Flomore beam clamp (included) to the power source, such as a walking beam. Insert rod or pipe in the beam clamp and the Item #12 connecting knuckle on the lever arm, tighten set screws to secure position of rod or pipe.
 - Wire line. Simply attach to walking beam and Item #12 connecting knuckle.
5. Fill the Item #10 box assembly with enough SAE-30 oil to cover the bearing. If low ambient temperatures are encountered a lighter oil such as SAE-10 should be used. Check oil level at regular intervals.

6. Adjust for desired volume by considering each of the following:
 - Number of strokes of lever arm. The fastest recommended operating speed is 50 strokes per minute. Refer to the volume chart (Page 7) to obtain desired setting of ratchet teeth engagement and stroke length at strokes per minute used.
 - Number of ratchet teeth engaged per stroke is dependent upon the travel of the B-0067 lever arm. With the Item #12 connecting knuckle in the outermost position, a travel of approximately 1" will engage one tooth. A maximum of 19" will engage twenty teeth.

NOTE: When the lever arm cannot travel below the level of the bottom of the base, the maximum teeth engagement will be 10.

- Adjustment of stroke length to short, medium, or long is easily accomplished by positioning of the A-0290 cotter pin in the end of the plunger.

NOTE: A quick calculation of (6A, 6B, and 6C) and using the performance data chart (Page 7) can predetermine the injection rate before the pump is placed in operation. If more volume is required, the pump head assembly can be changed or converted to a larger pump size. Or, an additional head can be installed on the opposite side of the B-0091 box by removing the A-0434 guide plug assembly. The A-0883 guide sleeve should also be removed and this can be accomplished with a vise to hold the crosshead and vise grips to turn and pull the guide sleeve.

7. Start pumping unit and prime pump head by opening the priming valve. After the pump discharges clear fluid without bubbles, close the priming valve for normal operation. At this point, make a visual check of the plunger drip, and using the gland wrench that is included in the package, slowly tighten the gland to prevent excess drippage and waste of chemicals. Do not overtighten plunger packing. Keep the gland wrench handy for future packing adjustment. It may be necessary to readjust the packing the next day. A slight leak during the break-in is beneficial. Sufficient time should be allowed to let the packing "seat in".

NOTE: If low volumes are being pumped, the pump head, the fluid discharge line and all other fittings up to the line check should be thoroughly purged of all air bubbles. Check pump action by opening the priming valve.

1300 Series Components

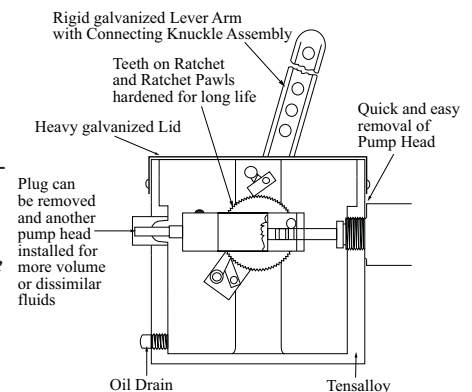
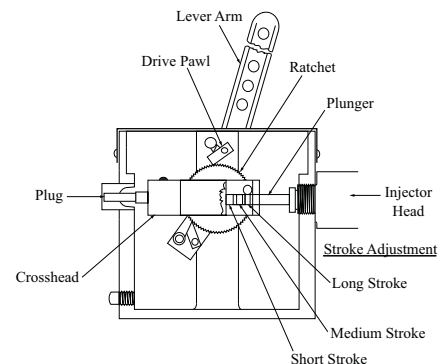

Handle Positions

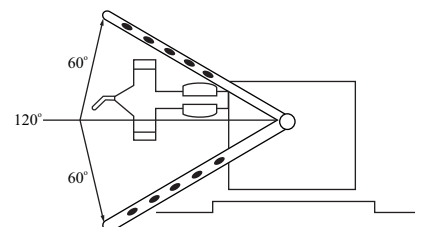

1300 Series Components

A-0676 Line Check

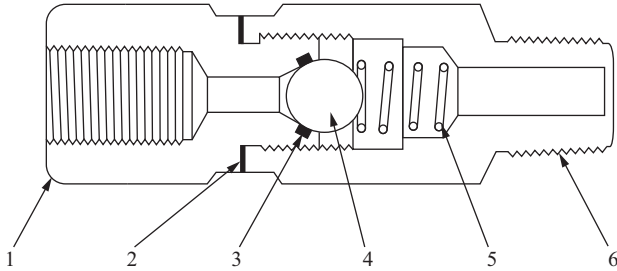

Parts List

Item #	Part #	Description	Material
1	A-0678	Inlet Body	Bronze
2	A-0479	O'Ring	Buna-N
3	A-0054	Ball	Stainless Steel
4	A-0391	Spring	Stainless Steel
5	A-0677	Outlet Body	Bronze

Injector Parts

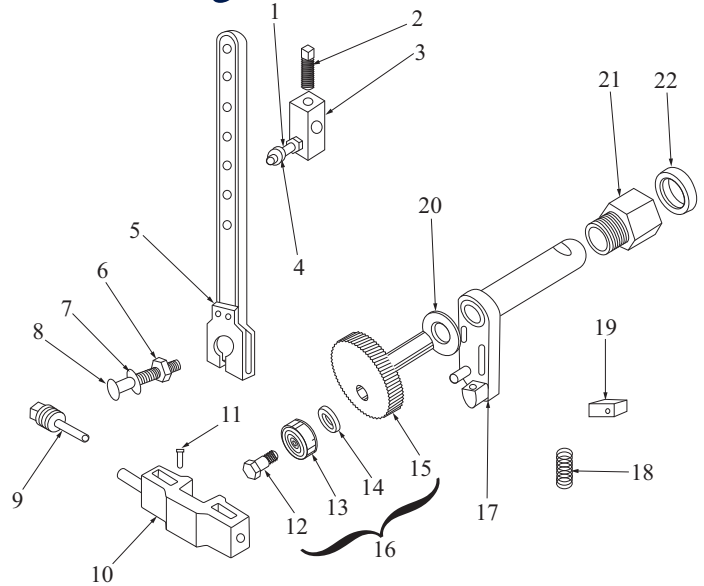

Parts List

Item #	Part #	# Req'd.	Description	Material
1	A-0438	1	Cap Screw	Steel
2	A-0452	1	Set Screw	Steel
3	A-0409	1	Knuckle	Aluminum
4	A-0439	1	Nut	Steel
5	B-0067	1	Lever Arm	Steel
6	A-0144	1	Nut	Steel
7	A-0425	1	Lock Washer	Steel
8	A-0424	1	Lever Bolt	Steel
9	A-0434	1	Guide Plug Assembly	Steel
10	A-0536	1	Cross Head (Simplex)	Ductile Iron
	A-0451		Cross Head (Duplex)	Ductile Iron
11	A-0290	1	Plunger Pin	Steel
12	A-0433	1	Ratchet Bearing Bolt	Steel
13	A-0457	1	Ratchet Bearing	Steel
14	A-0458	1	Cut Washer	Steel
15	A-0420	1	Ratchet Subassembly	Steel
16	A-0537	1	Ratched Assembly	Steel
17	B-0066	1	Drive Shaft	Steel
18	A-0456	2	Pawl Spring	Stainless Steel
19	A-0455	2	Pawl	Steel
20	A-4251	1	Nylon Washer	Nylon
21	A-5199	1	Shaft Bearing	Steel
22	A-5200	1	Seal	Neoprene

Not Required for Duplex Pump

Standard Box Assembly

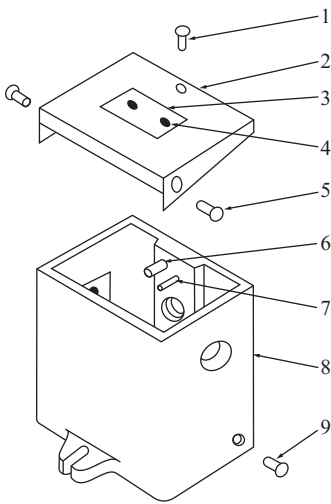

Parts List

Item #	Part #	Description	Material
1	A-2577	Thumb Screw	Steel
2	A-0960	Lid	Steel
3	A-0172	Name Plate	Aluminum
4	A-0171	Escutcheon Pin	Brass
5	A-0528	Rivet	Steel
6	A-0986	Check Pawl Spring Shaft	Steel
7	A-0985	Check Pawl Shaft	Steel
8	B-0091	Box Assembly	Aluminum
9	A-0138	Drain Plug	Iron

1300 Series Components

A-0701 Beam Clamp Assembly

Carbon Steel

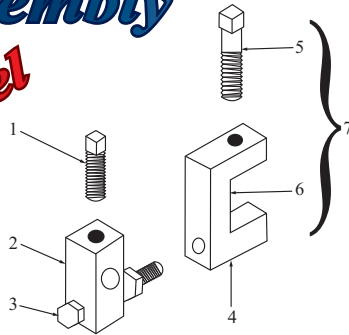

Parts List

Item #	Part #	Description	Material
1	A-0452	Set Screw	Steel
2	A-0409	Connecting Knuckle	Aluminum
3	A-0438	Cap Screw	Steel
4	A-0439	Hex Nut	Steel
5	A-0453	Set Screw	Steel
6	A-0423	Beam Clamp	Carbon Steel
7	A-0547	Beam Clamp Subassembly	◆

Dimensions

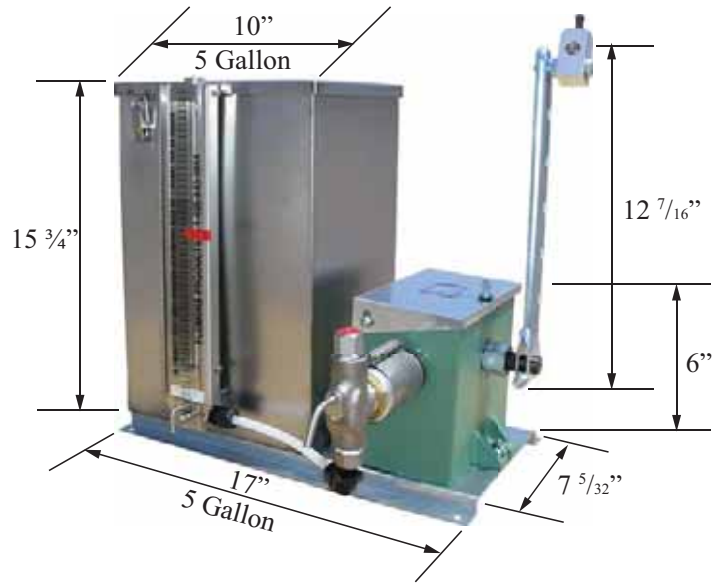

F-0871 Tank Gauge

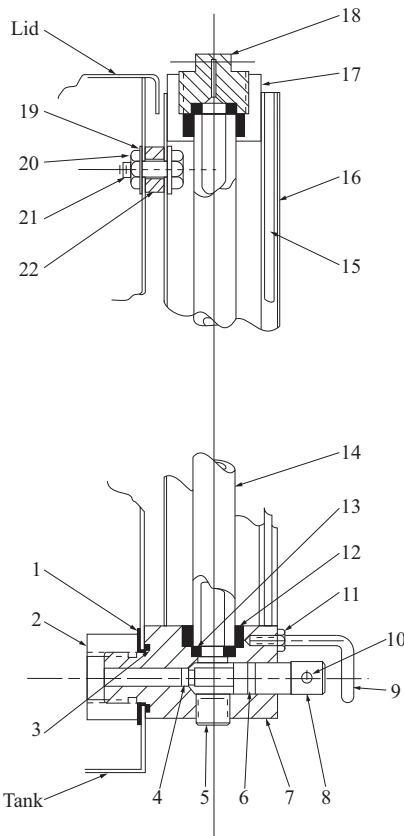

Item #	Part #	# Req'd.	Description	Material
1	A-0306	1	Washer	Teflon
2	F-0871.01	1	3/4-16" Nut	Stainless Steel
3	F-0871.03	1	2-019 O'Ring	Viton
4	F-0871.04	1	2-006 O'Ring	Viton
5	A-0138	2	1/4" NPT Pipe Plug	Steel
6	F-0871.06	1	2-011 O'Ring	Viton
7	F-0871.07	1	Valve Body	Stainless Steel
8	F-0871.08	1	Valve Stem	Stainless Steel
9	F-0871.11	1	Valve Stop	Stainless Steel
10	F-0871.09	1	1/8" x 2" Roll Pin	Stainless Steel
11	F-0871.10	1	Valve Stop Nut	Stainless Steel
12	15470	2	Tube Gasket	Buna-N
13	D-0013	2	Tube End Seal	Viton
14	A-3102	1	Glass Tube	Glass
15	F-0871.15	1	Scale	Acrylic
16	F-0871.16	1	Housing	Stainless Steel
17	F-0871.17	1	Top Block	Aluminum
18	F-0871.18	1	Vent Plug	Stainless Steel
19	A-4092	2	Stat-O-Seal	Steel
20	F-0871.20	1	1/4-20" Nut	Stainless Steel
21	F-0871.21	1	1/4-20" x 3/4" Bolt	Stainless Steel
22	A-0987	1	Spacer	Stainless Steel

Injector Heads

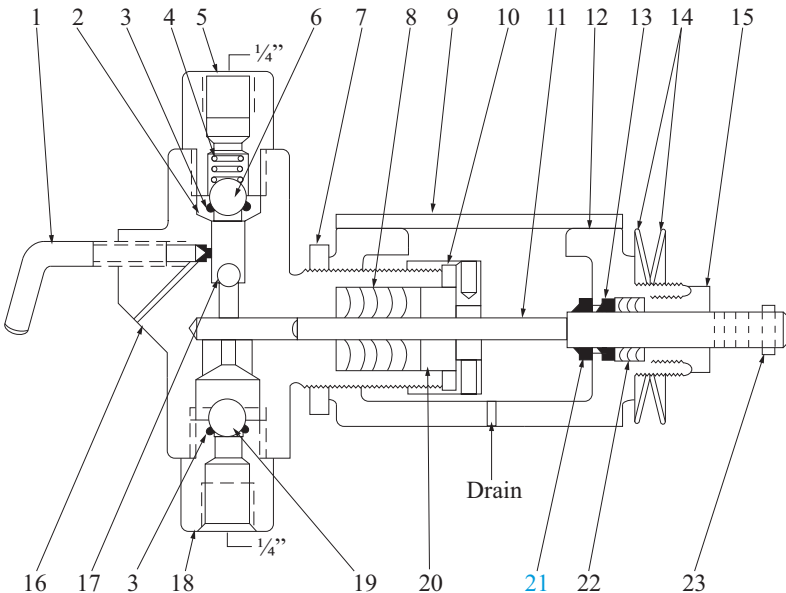

Note: Drip Ring moves with the Plunger.

Parts List

Alternate Construction

Item #	Part #	Description	Material
2	A-0806	Top Seat Assembly (Metal-to-Metal)	303 Stainless Steel
3	A-2580	O'Ring	Viton
8	A-4102	1/4" Plunger Packing	Viton
	A-1642		Teflon
	A-2295		Hard
	A-4101	3/8" Plunger Packing	Viton
	A-1234		Teflon
	A-1875		Hard
	A-4103	1/2" Plunger Packing	Viton
	A-1012		Teflon
A-1874	Hard		
18	A-0771	Bottom Seat Assembly (Metal-to-Metal)	303 Stainless Steel
19	A-0053	1/2" Ball	316 Stainless Steel

Item #	Part #			# Req'd.	Description	Material
	1/4"	3/8"	1/2"			
---	C-1578	C-1579	C-1580	1	Head Assembly	Ductile Iron with Stainless Steel Trim
	C-1582	C-1583	C-1584			All Stainless Steel
1		A-1497		1	Priming Valve	303 Stainless Steel
*2		B-0737		1	Top Seat Assembly	303 Stainless Steel
*3		A-0479		1	O'Ring	Buna-N
4		A-0077		1	Ball Check Spring	316 Stainless Steel
5		A-1496		1	Top Bushing	302 Stainless Steel
6		A-0054		1	3/8" Large Top Ball	316 Stainless Steel
7		A-0225		1	Yoke Lock Nut	Brass
*8	A-1461	A-1456	A-0959	1	Plunger Packing Set	Buna-N
9		C-1604		1	Yoke Cover	303 Stainless Steel
10		A-4104		1	Plunger Packing Gland Nut	303 Stainless Steel
*11	B-1175	B-1176	B-1177	1	Plunger	17-4 pH Stainless Steel
12		B-1173		1	Yoke	Malleable Iron
13		A-4095		1	Plunger Wiper Ring	Buna-N
14		A-4256		2	Belleville Washer	302 Stainless Steel
15		A-4094		1	Yoke Packing Nut	Brass
16	C-0275	C-0276	C-0272	1	Body	Ductile Iron
	C-0291	C-0425	C-0349			Stainless Steel
17		A-0126		1	1/4" Small Top Ball	316 Stainless Steel
*18		B-0736		1	Bottom Seat	303 Stainless Steel
*19		A-0054		1	3/8" Suction Ball	316 Stainless Steel
20	A-1463	A-0957	A-1219	1	Plunger Packing Gland	303 Stainless Steel
21		A-4095		1	Plunger Drip Ring	Buna-N
22		A-4127		1	Yoke Packing Set	Buna-N
23		A-0290		1	Pin Plunger	Carbon Steel

*Recommended Spare Parts

*Alternate Components Available (see table above)

Performance Data and Maintenance

Volume Output

*NOTE: For volumes with additional ratchet teeth engaged, multiply these values by the number of teeth engaged. Twenty teeth maximum pickup. Minimum values are theoretical only.

Strokes Per Minute	*Ratchet Teeth Engaged	¼" Plunger			⅜" Plunger			½" Plunger		
		Short Stroke	Medium Stroke	Long Stroke	Short Stroke	Medium Stroke	Long Stroke	Short Stroke	Medium Stroke	Long Stroke
6	1	0.04	0.08	0.12	0.10	0.20	0.30	0.17	0.35	0.50
8	1	0.06	0.10	0.16	0.14	0.26	0.40	0.23	0.47	0.70
10	1	0.07	0.13	0.20	0.17	0.33	0.50	0.29	0.59	0.80
12	1	0.08	0.16	0.24	0.20	0.40	0.60	0.35	0.71	1.00
14	1	0.10	0.18	0.28	0.24	0.46	0.70	0.40	0.83	1.20
16	1	0.11	0.21	0.32	0.27	0.53	0.80	0.46	0.94	1.40
18	1	0.13	0.23	0.36	0.31	0.59	0.90	0.52	1.06	1.50

*Volume in Pints per Day

Pressure Volume Range

*NOTE: For double headed units, increase maximum volume by two.

Plunger Size	Maximum Discharge Pressure	Model #	Pints per Day	
			Minimum Volume	Maximum Volume
¼"	1500	13-01	0.5	7.2
⅜"	1000	13-03	0.5	18.0
½"	500	13-05	1.0	30.0

Maintenance

To Remove B-0067, Page 4

Remove A-0414 lever bolt assembly. B-0067 lever can then be removed from the B-0066 drive shaft assembly. Upon re-assembly, be sure the bolt fits into the slot in the end of the drive shaft assembly.

To Remove A-0536 Crosshead, Page 4

It is not necessary to remove the pump head from a single-headed unit in order to remove the crosshead if the following steps are taken.

1. Hand operate B-0067 lever until plunger is at its full discharge position.
2. Pull A-0290 pin (disconnecting plunger from A-0536 crosshead).
3. Remove A-0434 guide plug assembly.
4. Hand operate lever until plunger is free of crosshead. Lift out crosshead. To remove crosshead from double-headed unit, it is necessary to remove one pump head from the gear box.

To Remove A-0537 Ratchet Sub-Assembly, Page 4

It is necessary to follow both procedures outlined above.

1. After crosshead is removed, A-0537 sub-assembly may be pulled toward center of gear box and lifted out.
2. To remove A-0457 bearing and A-0458 washer from A-0420 ratchet assembly, unscrew A-0433 bearing bolt.
3. To remove B-0066 drive shaft assembly, follow the procedure outlined above.
4. Unscrew the A-5199 shaft bearing. B-0066 drive shaft assembly can then be lifted out through the gear box.

Installing A-5200 Shaft Seal in A-5199 Shaft Bearing, Page 4

The A-5200 seal is pressed into the A-5199 bearing. When done correctly, the garter spring will not be visible on the assembly.

Replacing Ratchet Pawls A-0455 and Ratchet Pawl Springs A-0456, Page 4

It is necessary to remove A-0537 ratchet sub-assembly.

To Repack Fluid Pump Head, Page 4 and 6

1. Disconnect chemical suction line.
2. Pull A-0290 pin.
3. Entire fluid head can now be unscrewed from gear box.
4. Loosen gland nut.
5. Pull plunger from head.
6. Remove A-4094 packing nut. This gives access to the yoke packing.
7. Loosen A-0225 lock nut. Yoke can then be unscrewed from fluid head (while unscrewing the yoke, the gland nut must also be backed-off). At this point, wiper washer, gland nut, and packing gland nut can be removed. This gives access to the main plunger packing.

To Check Discharge Ball, Seat, Springs and O'Ring, Page 4

Remove A-1496 top bushing.

To Check Suction Ball, Page 4

Remove B-0736 bottom bushing (o'ring is integral part of B-0736 suction bushing).