

***FLOMORE***

*Different By Design*

# ***4400 Series Injector***

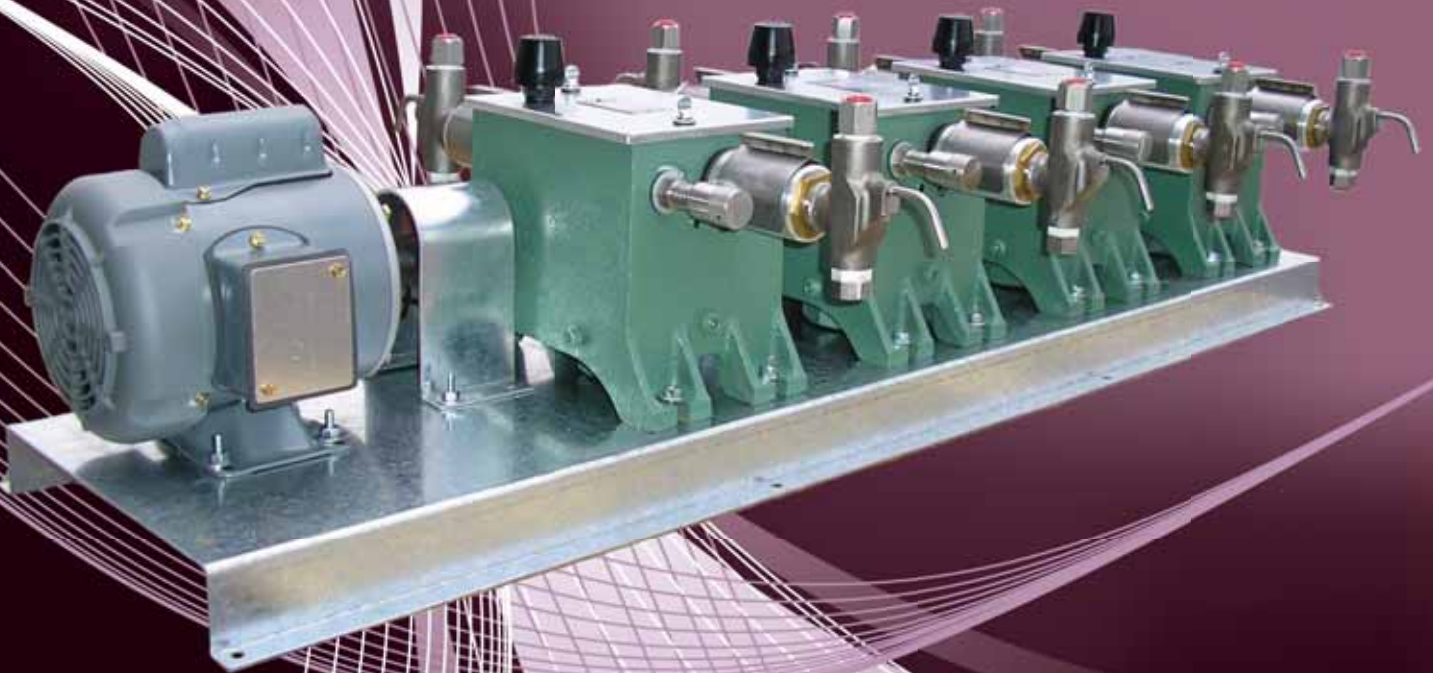

# 4400 Series Injector

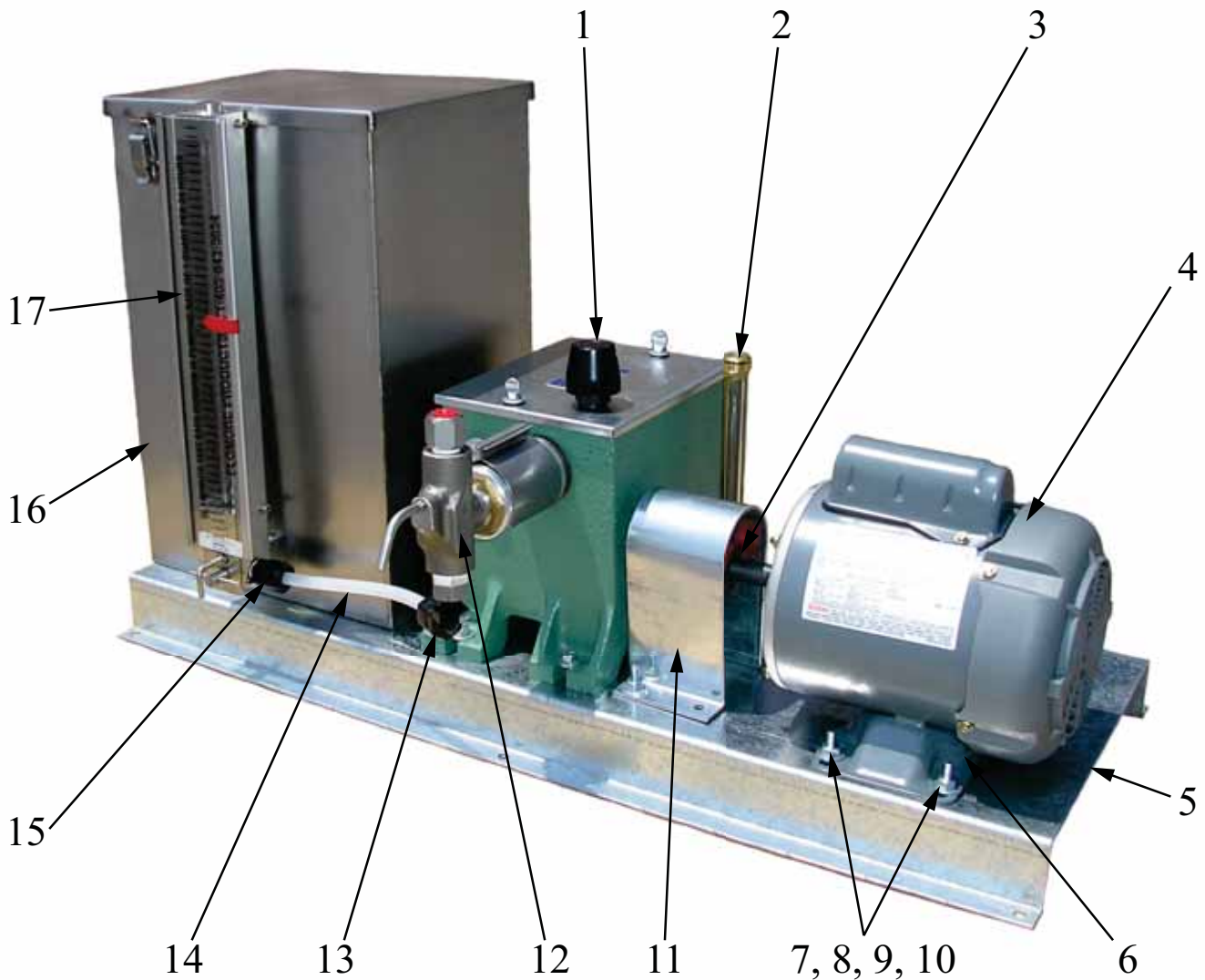

## Parts List

Item #	Part #	Description
1	A-2600	Breather
2	A-4066	Oil Gauge Assembly
3	A-1653	½" x ⅝" Coupling
4	A-2264	¼ HP, 1ph, 60 Hz, 115/230 Volt, TEFC
	A-2268	¼ HP, 3ph, 60 Hz, 230/460 Volt, TEFC
	A-2265	¼ HP, 1ph, 60 Hz, 115/230 Volt, Ex. Proof
	A-2271	¼ HP, 3ph, 60 Hz, 230/460 Volt, Ex. Proof
5	B-0431	Base for Two 5 Gallon Tanks and Pump
	B-0436	Base for One 5 Gallon Tank and Pump
	B-0437	Base for Pump
6	A-1741	Spacer for 48 Frame Motor Only

Item #	Part #	Description
7	A-0164	Hex Nut
8	A-3303	¼" Steel Lockwasher
9	A-0167	Cut Washer
10	A-0163	Cap Screw
11	B-1167	Coupling Guard
12	See Page 9	Head Assembly
13	A-3116	Elbow
14	A-3117	Polypropylene Tube
15	A-3118	Connector
16	A-0664	5 Gallon 430 Stainless Steel Chemical Tank
17	F-0871	Tank Gauge Assembly for 5 Gallon Tank

# Operating Instructions and Dimensions

## Operating Instructions

**Note:** The motor needs to be wired to turn the shaft of the pump clockwise.

1. Check oil level in gear box regularly. Observe oil level indicator Item #21 Page 6.
2. Check for excess chemical leakage around the packing gland. If it is impossible to tighten, replace the packing. If the plunger is badly scored, replace the plunger and packing. If excessive packing failure is experienced, consult your Flomore representative.
3. Each Flomore Series 4400 Pump has an adjustment for the required stroke length. To adjust stroke length see the *Flow Rate Adjustment* instruction note on page 4.

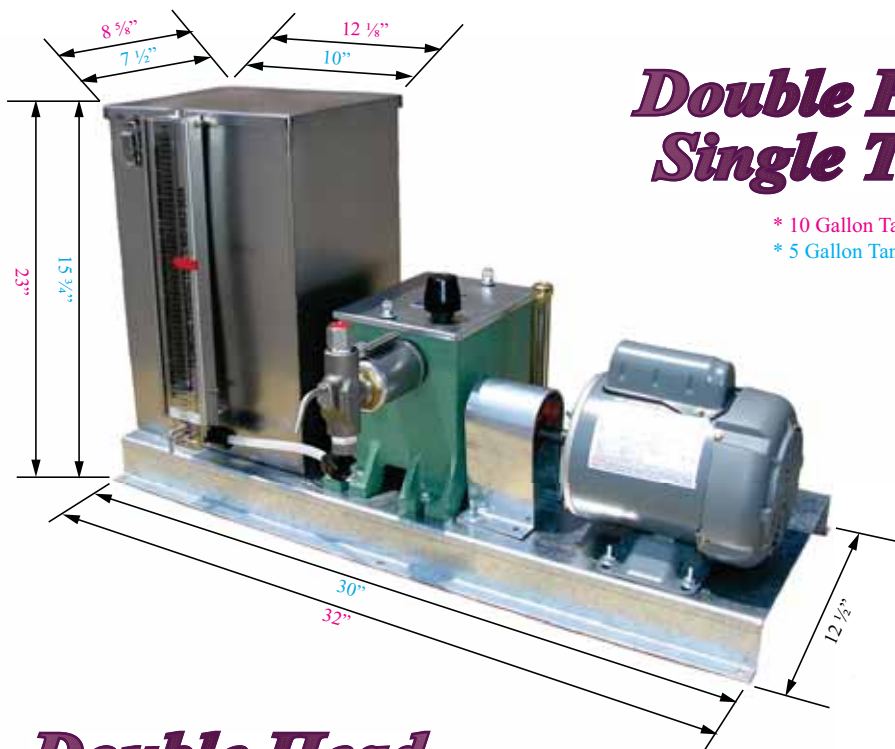

## Double Head Single Tank

- \* 10 Gallon Tank
- \* 5 Gallon Tank

## Double Head Double Tank

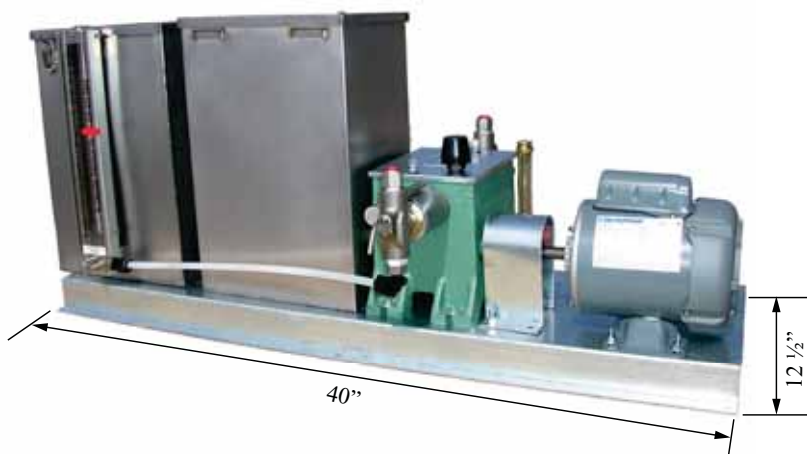

## Single Head

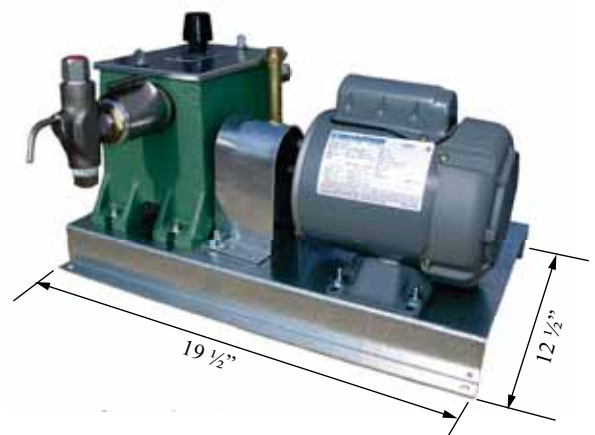

# ***Gear Box Assembly***

## ***Side View***

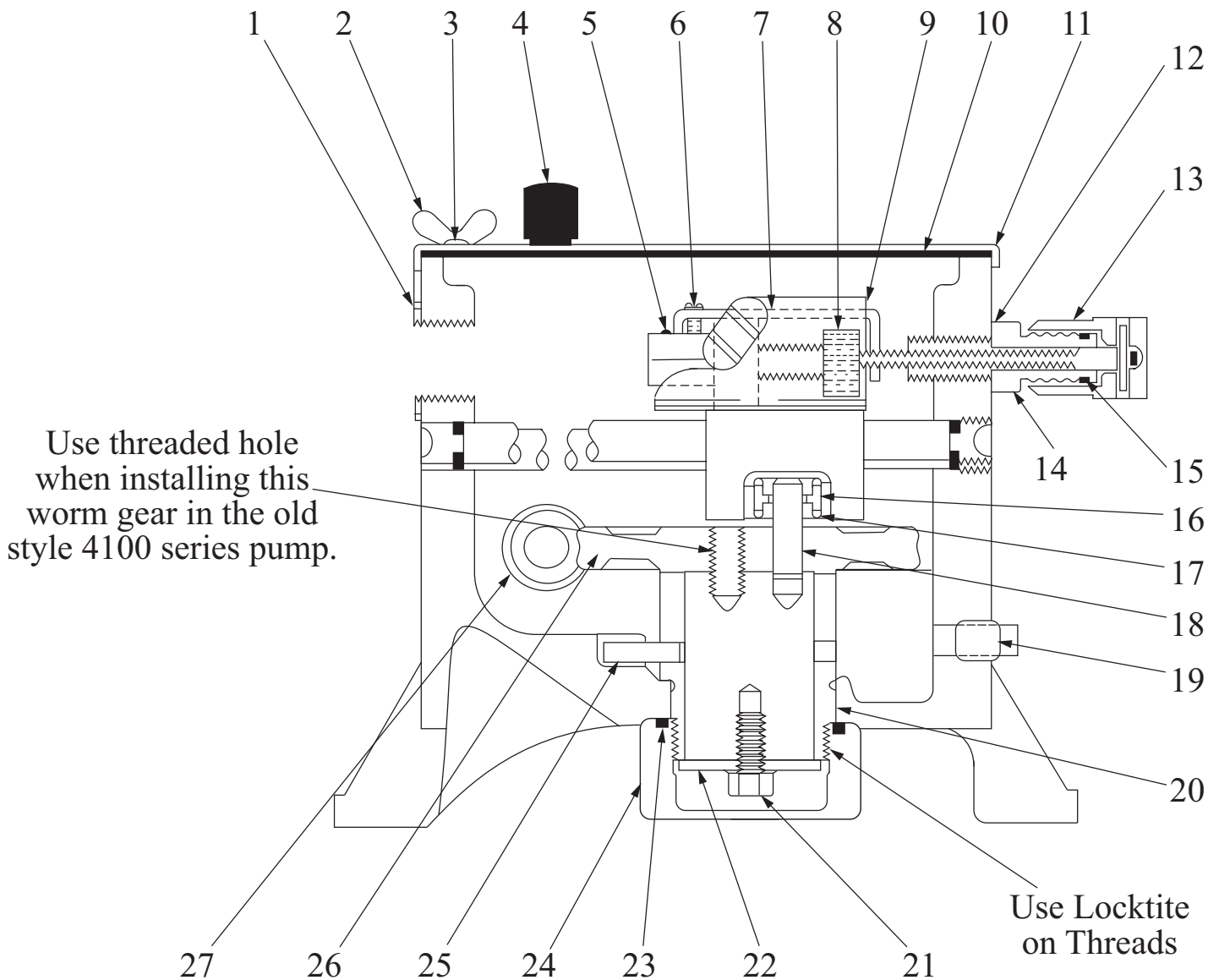

### ***Flow Rate Adjustment***

*Turn knob, Item #14, clockwise to decrease flow, counterclockwise to increase flow. Each complete turn of the knob results in a 10% change in stroke setting. Each groove on the spindle, Item #15 Page 4, is equal to 25% change in stroke setting. To adjust pump while stopped, make sure plunger is in the full forward position.*

# Gear Box Assembly

## Parts List

Item #	Part #	# Reqd.	Description	Material
1	A-4256	2	Belleville Washer	302 Stainless Steel
* 2	A-2970	2	Wing Screw	Cadmium Plated Carbon Steel
3	A-4092	2	¼" Stat-O-Seal	Buna-N
4	A-2600	1	Breather	♦
* 5	A-0290	1	Plunger Pin	Carbon Steel
* 6	A-3312	1	Lockwasher	Cadmium Plated Steel
	A-4753		Round Head Screw	
7	A-4756	1	Guide Bar	Carbon Steel
8	A-4757	1	Stroke Adjustment Gear	Nylon
9	A-4758	1	Stroke Adjustment Drive Gear	Nylon
10	A-4814	1	Cover Gasket	Neoprene
11	C-1576	1	Cover	Galvanized Carbon Steel
12	A-4759	1	Gasket	Buna-N
13	A-4805-A	1	Stroke Adjustment Knob & Screw Assembly	Steel
14	A-4761	1	Stroke Adjustment Spindle	303 Stainless Steel
15	A-1957	1	O'Ring	Buna-N
16	A-4065	1	Crosshead Bearing	Carbon Steel
17	A-0458	1	Washer	Carbon Steel
18	A-4064	1	Bearing Stud	Carbon Steel
19	A-0138	1	Pipe Plug	Galvanized Malleable Iron
* 20	B-0619	1	Lower Bearing	Ductile Iron
* 21	A-2501	1	Machine Screw	Carbon Steel
	A-0459		⅜" Spring Lockwasher	
* 22	A-1930	1	Bottom Thrust Washer	Carbon Steel
* 23	A-2457	1	O'Ring	Buna-N
* 24	A-1921	1	Cap	Carbon Steel
* 25	A-2337	1	Roll Pin	Cadmium Plated Carbon Steel
* 26	B-0621	1	Worm Gear (25:1 Ratio)	Cast Iron
	B-0616		Worm Gear (50:1 Ratio)	
	B-0623		Worm Gear (100:1 Ratio)	
* 27	A-1871	1	Worm & Shaft Assembly (25:1 Ratio)	Carbon Steel
	A-2250		Worm & Shaft Assembly (50:1 Ratio)	
	A-1755		Worm & Shaft Assembly (100:1 Ratio)	
♠	B-0270	1	Thru-Shaft Assembly (25:1 Ratio)	Carbon Steel
	B-0469		Thru-Shaft Assembly (50:1 Ratio)	
	B-0452		Thru-Shaft Assembly (100:1 Ratio)	

*\* Recommended Spare Parts*

*\* Parts are directly interchangeable with Series 4100, 4200 and 4300 Pumps*

*♠ Parts used when a common motor is used to drive more than one Gear Box Assembly*

# ***Gear Box Assembly***

## ***Top View***

*\* Apply Lubriplate 630 AA or equal*

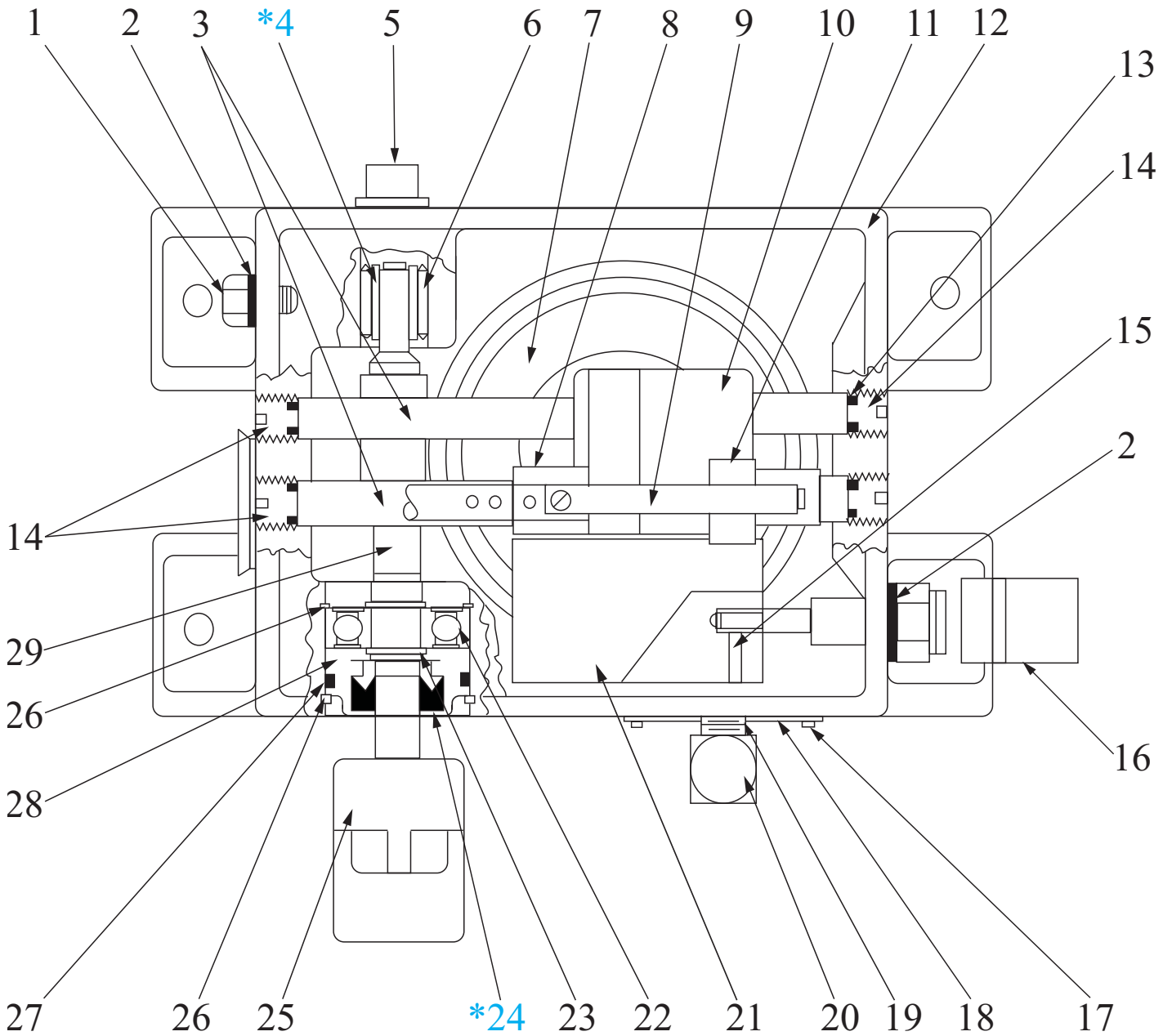

*\* Apply Lubriplate 630 AA or equal between shaft and seal lips*

*\* Assembly oil seal flush with end of cartridge*

# Gear Box Assembly

## Parts List

Item #	Part #	# Reqd.	Description	Material
1	A-4795	1	Bolt	Cadmium Plated Steel
2	A-4759	1	Gasket	Buna-N
3	A-4229	2	Crosshead Guide Bar	Carbon Steel
* 4	A-2287	1	Inner Race Bearing	Carbon Steel
5	A-3309	1	Pipe Plug	Galvanized Malleable Iron
* 6	A-2286	1	Bearing Needle	Carbon Steel
7	B-0621	1	Worm Gear (25:1 Ratio)	Cast Iron
	B-0616		Worm Gear (50:1 Ratio)	Cast Iron
	B-0623		Worm Gear (100:1 Ratio)	Cast Iron
8	A-4755	1	Adjustment Bolt	Carbon Steel
9	A-4756	1	Guide Bar	304 Stainless Steel
10	B-1333	1	Crosshead	Cast Iron
11	A-4757	1	Stroke Adjustment Gear	Nylon
12	D-0492	1	Housing	Cast Iron
13	A-3849	4	O'Ring	Buna-N
14	A-4228	4	Rod Retainer	Carbon Steel
15	A-4894	1	Set Screw	Steel
16	A-4805-A	1	Stroke Adjustment Knob & Screw Assembly	Steel
17	A-0171	2	Escutcheon Pin	Brass
18	A-0172	1	Name Plate	Aluminum
19	A-3325	1	¼" Nipple	Cadmium Plated Carbon Steel
20	A-4066	1	Oil Gauge Assembly	Brass with Glass Tube
21	A-4758	1	Stroke Adjustment Drive Gear	Nylon
* 22	A-2285	1	Ball Bearing	Carbon Steel
* 23	A-3310	2	Truarc Ring	Carbon Steel
♠ * 24	A-2064	1	Seal	Buna-N
* 25	A-1653	1	½" x ⅝" Coupling (56 Frame Motor)	Carbon Steel
♠	A-1836	1	½" x ½" Coupling (48 Frame Motor)	Carbon Steel
* 26	A-3311	2	Truarc Ring	Carbon Steel
27	A-1961	1	O'Ring	Buna-N
28	A-4045	1	Seal Cartridge	Carbon Steel
♠	A-2036	1	Bearing	Brass
* 29	A-1871	1	Worm & Shaft Assembly (25:1 Ratio)	Carbon Steel
	A-2250		Worm & Shaft Assembly (50:1 Ratio)	
	A-1755		Worm & Shaft Assembly (100:1 Ratio)	
♠	B-0270	1	Thru-Shaft Assembly (25:1 Ratio)	Carbon Steel
	B-0469		Thru-Shaft Assembly (50:1 Ratio)	
	B-0452		Thru-Shaft Assembly (100:1 Ratio)	

*\* Recommended Spare Parts*

*\* Parts are directly interchangeable with Series 4100, 4200 and 4300 Pumps*

*♠ Parts used when a common motor is used to drive more than one Gear Box Assembly*

# 4400 Series Components

## A-0675 & A-0676 Line Check

### Parts List

Item #	Part #	# Reqd.	Description	Material
1	A-0678	1	Inlet Body	Brass
	A-1297	1	Inlet Body	303 Stainless Steel
2	A-1574	1	Washer	304 Stainless Steel
3	A-0479	1	O'Ring	Buna-N
	A-2580	1	O'Ring	Viton
4	A-0054	1	3/8" Ball	316 Stainless Steel
5	A-0391	1	Spring	Steel
6	A-0679	1	Outlet Body	Brass
	A-1296	1	Outlet Body	303 Stainless Steel

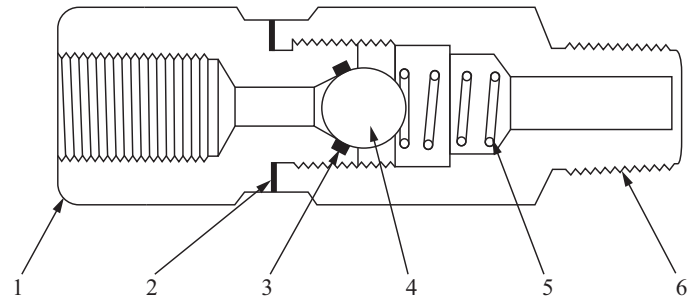

\* Recommended Spare Parts

\*\*A-0675 Only

\*\*\*A-0676 Only

## F-0871 Tank Gauge

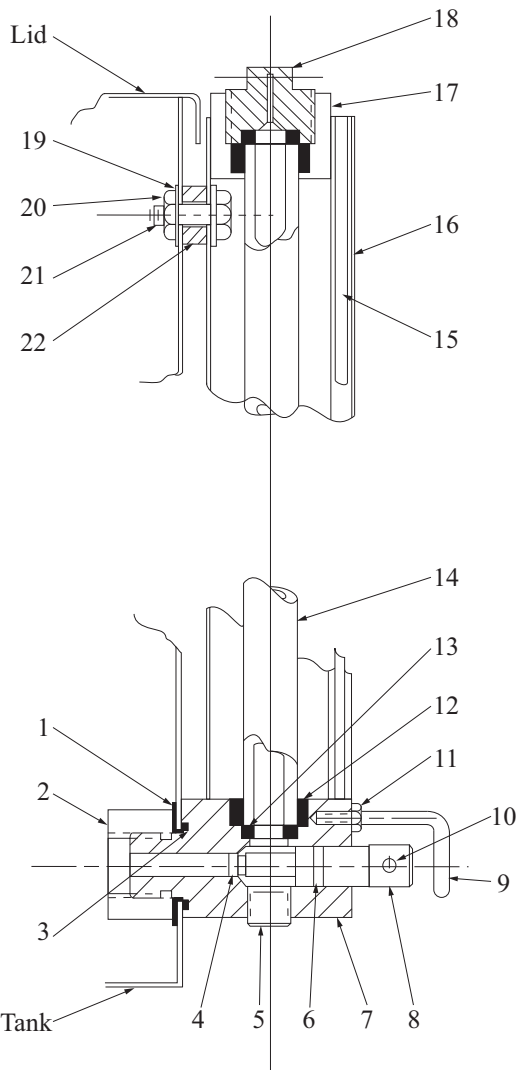

### Parts List

Item #	Part #	# Reqd.	Description	Material
1	A-0306	1	Washer	Teflon
2	F-0871.01	1	3/4-16" Nut	Stainless Steel
3	F-0871.03	1	2-019 O'Ring	Viton
4	F-0871.04	1	2-006 O'Ring	Viton
5	A-0138	2	1/4" NPT Pipe Plug	Steel
6	F-0871.06	1	2-011 O'Ring	Viton
7	F-0871.07	1	Valve Body	Stainless Steel
8	F-0871.08	1	Valve Stem	Stainless Steel
9	F-0871.11	1	Valve Stop	Stainless Steel
10	F-0871.09	1	1/8" x 2" Roll Pin	Stainless Steel
11	F-0871.10	1	Valve Stop Nut	Stainless Steel
12	15470	2	Tube Gasket	Buna-N
13	D-0013	2	Tube End Seal	Viton
14	A-3102	1	Glass Tube	Glass
15	F-0871.15	1	Scale	Acrylic
16	F-0871.16	1	Housing	Stainless Steel
17	F-0871.17	1	Top Block	Aluminum
18	F-0871.18	1	Vent Plug	Stainless Steel
19	A-4092	2	Stat-O-Seal	Steel
20	F-0871.20	1	1/4-20" Nut	Stainless Steel
21	F-0871.21	1	1/4-20" x 3/4" Bolt	Stainless Steel
22	A-0987	1	Spacer	Stainless Steel



# Injector Heads

## Alternate Construction

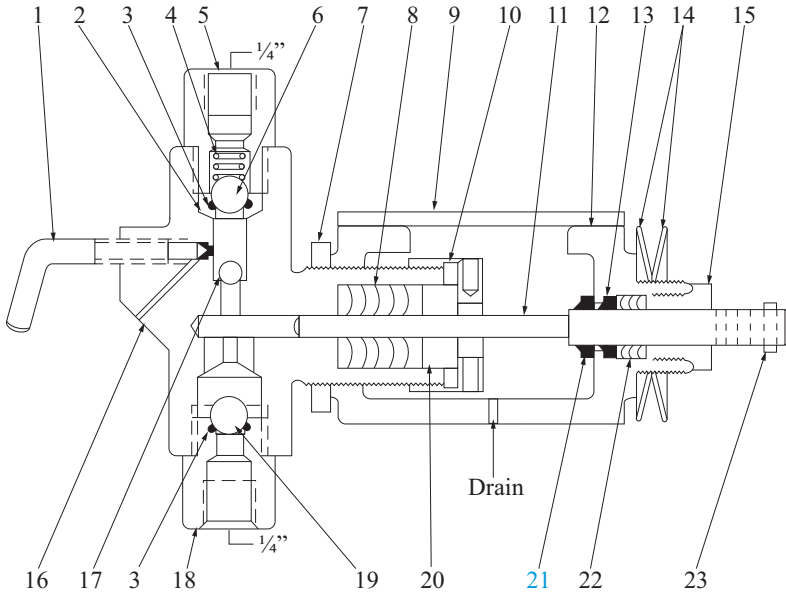

Note: Drip Ring moves with the Plunger.

Item #	Part #	Description	Material
2	A-0806	Top Seat Assembly (Metal-to-Metal)	303 Stainless Steel
	B-0843	Top Seat Assembly (Viton)	
3	A-2580	O'Ring	Viton
8	A-3967	3/16" Plunger Packing	Viton
	A-3966		Teflon
	A-4102		Viton
	A-1642	1/4" Plunger Packing	Teflon
	A-2295		Hard
	A-4101	3/8" Plunger Packing	Viton
	A-1234		Teflon
	A-1875		Hard
	A-4103	1/2" Plunger Packing	Viton
	A-1012		Teflon
A-1874	Hard		
11	B-1175-C	1/4" Ceramic Plunger	♦
	B-1176-C	3/8" Ceramic Plunger	
	B-1177-C	1/2" Ceramic Plunger	
18	A-0771	Bottom Seat Assembly (Metal-to-Metal)	303 Stainless Steel
	B-0844	Bottom Seat Assy. (Viton)	
19	A-0053	1/2" Ball	316 Stainless Steel

## Parts List

Item #	Part #				# Req'd.	Description	Material
	3/16"	1/4"	3/8"	1/2"			
♦	♦	C-1578	C-1579	C-1580	1	Head Assembly	Ductile Iron with Stainless Steel Trim
	C-2041	C-1582	C-1583	C-1584			All Stainless Steel
1	A-4027	A-1497			1	Priming Valve	303 Stainless Steel
*2	B-0737				1	Top Seat Assembly	303 Stainless Steel
*3	A-0479				1	O'Ring	Buna-N
4	A-0077				1	Ball Check Spring	316 Stainless Steel
5	A-1496				1	Top Bushing	302 Stainless Steel
6	A-0054				1	3/8" Large Top Ball	316 Stainless Steel
7	A-0225				1	Yoke Lock Nut	Brass
*8	A-3969	A-1461	A-1456	A-0959	1	Plunger Packing Set	Buna-N
9	C-1604				1	Yoke Cover	303 Stainless Steel
10	A-4104				1	Plunger Packing Gland Nut	303 Stainless Steel
*11	B-1288	B-1175	B-1176	B-1177	1	Plunger	17-4 pH Stainless Steel
12	B-1173				1	Yoke	Malleable Iron
13	A-4095				1	Plunger Wiper Ring	Buna-N
14	A-4256				2	Belleville Washer	302 Stainless Steel
15	A-4094				1	Yoke Packing Nut	Brass
16	♦	C-0275	C-0276	C-0272	1	Body	Ductile Iron
	C-2040	C-0291	C-0425	C-0349			Stainless Steel
17	♦	A-0126			1	1/4" Small Top Ball	316 Stainless Steel
*18	B-1216	B-0736			1	Bottom Seat	303 Stainless Steel
*19	A-0054				1	3/8" Suction Ball	316 Stainless Steel
20	A-4332	A-1463	A-0957	A-1219	1	Plunger Packing Gland	303 Stainless Steel
21	A-4095				1	Plunger Drip Ring	Buna-N
22	A-4127				1	Yoke Packing Set	Buna-N
23	A-0290				1	Pin Plunger	Carbon Steel

\*Recommended Spare Parts

\*Alternate Components Available (see table above)

# Performance Data

## Pressure Volume Range

# of Heads	Plunger Size	Maximum Discharge Pressure (PSI)	100:1 Ratio (17.5 SPM)			50:1 Ratio (35 SPM)			25:1 Ratio (70 SPM)					
			Model #	Min.* 60 Hz Motor	Max.* 50 Hz Motor	Model #	Min.* 60 Hz Motor	Max.* 50 Hz Motor	Model #	Min.* 60 Hz Motor	Max.* 50 Hz Motor			
Single Head Units	3/16"	◆	44-24	0.063	2.5	2.07	44-04	0.13	5	4.15	44-34	0.25	10	9.13
	1/4"	2400	44-21	0.50	5.0	4.15	44-01	1.0	10	8.30	44-31	2.0	20	16.60
	3/8"	1200	44-23	1.2	12	9.96	44-03	2.3	23	19.09	44-33	4.6	46	38.18
	1/2"	600	44-25	2.1	21	17.43	44-05	4.0	40	33.20	44-35	8.0	80	66.40
Double Head Units	3/16"	◆	43-24	0.13	5.0	4.14	43-04	0.26	10	8.3	43-34	0.5	22	18.20
	1/4"	2400	43-21	1.0	10	8.30	43-01	2.0	20	16.60	43-31	4.0	40	33.20
	3/8"	1200	43-23	2.4	24	19.90	43-03	4.6	46	38.18	43-33	9.2	92	76.40
	1/2"	600	43-25	4.2	42	34.86	43-05	8.0	80	66.40	43-35	16.0	160	132.8

\*Volume expressed in U.S. Gallons Per Day

## Horsepower Requirements for Mult-Headed Units

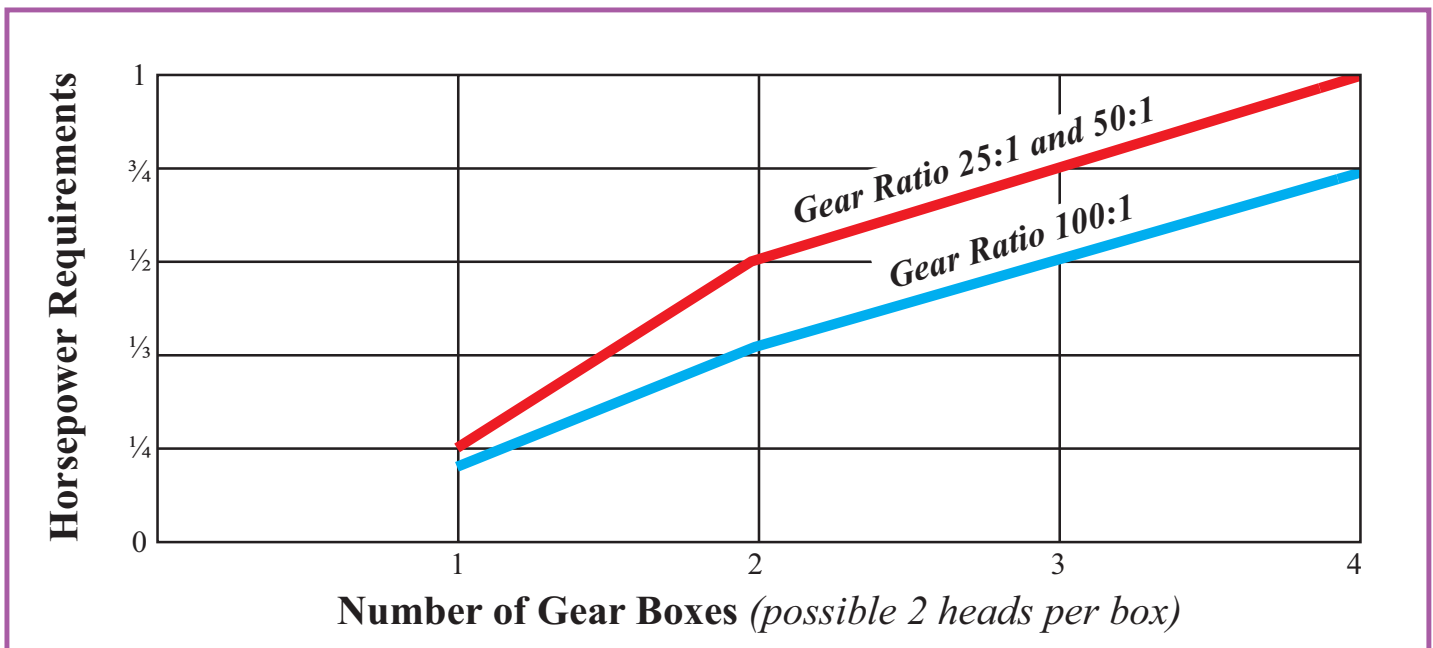

# ***Maintenance***

## ***Replacing the Stroke Adjustment Gears, Page 7***

1. When replacing the steel stroke adjustment gears, they have to be correctly positioned relative to the crosshead, the stroke adjustment knob, and to each other. Rotate the motor coupling by hand until the crosshead, Item #11, is moved forward as far as it will go toward the side of the housing in which the head is mounted.
2. Assemble the small and large gears, Items #12 & 22, in place. Leave the set screw, Item #16, in the large gear, loose for the time being. The two gears should be in mesh at this point, and rotating the large gear by hand will cause the small gear to move forward and back on the adjustment bolt, Item #9.
3. Turn the large gear in the direction that causes the small gear to move forward toward the crosshead, and continue this turning motion until the small gear is flush up against the crosshead (no lost motion).
4. Now turn the stroke adjustment knob, Item #17, clockwise until it covers the last groove on the spindle, then tighten the set screw, Item #16, in the large steel gear, using a 5/64" Allen wrench.

The pump is now set in full discharge stroke position, and all parts are in their correct relative positions. To make further adjustment in the flow rate, see the Flow Rate Adjustment instructions on Page 4.

## ***Disassembly of the Power Mechanism, Page 7***

1. Disconnect and remove pump head from power unit.
2. Remove Item #22, large steel drive gear, by loosening Item #16, set screw, with a 5/64" Allen wrench.
3. Remove Item #15, rod retainers, and Item #14, o'rings, from each end of Item #4, bearing rods.
4. Using proper size punch, push bearing rods through Item #11, crosshead, and out opposite side of gear box.

## ***Remove Worm Gear and Bearing from Gear Box, Page 5***

1. Remove cap, Item #25, from bottom of pump.
2. Remove Item #22, hex-head machine screw and spring washer and Item #23, bottom thrust washer. You can now remove the worm gear, Item #27, and Item #21, bearing, through the top of the housing.
3. Upon replacing, be certain the gear roll pin, Item #26, is located in its proper place -- holding the bearing, Item #21, in proper alignment.

## ***To Remove Crosshead Bearing from Worm Gear, Page 7***

Remove Item #11, crosshead, and lift bearing off of Item #19, bearing stud.

## ***To Remove the Worm Gear and Shaft, Shaft End Bearing, and/or Oil Stem, Page 7***

*It is not necessary to remove crosshead, guide rods, or worm gear in order to remove the drive shaft and its component parts.*

1. Disconnect flexible coupling and remove motor from base. If unit is equipped with container on base, it is best to remove entire gear box from base:
  - a. Remove Item #27, truarc ring.
  - b. Remove Item #6, pipe plug.
2. Insert proper size punch into recess on small end of Item #8, shaft, (small end under Item #6, pipe plug). Carefully drive shaft out through opposite side of housing. Punch size should be small enough so not to drive against Item #5, inner race, (if it is desirable to remove Item #7, needle bearing, and Item #5, inner race, it should be done after the shaft has been removed).
3. As the shaft is being driven out, care should be taken to see that the large gear worm turns. This will "walk" or disengage the gear teeth.
4. As the shaft emerges from the side of housing, it will force out the oil seal, Item #25, seal cartridge, Item #29, and ball bearing, Item #23.
5. Withdraw the shaft from pump housing.
6. In order to remove ball bearing, Item #23, from shaft, it is necessary to remove one or both truarc rings, Item #24.
7. Upon replacing, care should be taken to "walk" the two worm gears back together.
8. Be sure the two truarc rings, Item #24, are in place: also seal and seal housing are in properly (the seal lips and seal expander spring should face into the pump). Make sure the o'ring, Item #28, is in its proper place.
9. The shaft assembly should be inserted into the pump until shaft bearing, Item #23, shoulders against the truarc ring, Item #24, located near the inner edge of the hole into which the shaft is inserted.

## ***Apply Lubriplate 630 SS to wear surfaces of the following items, Page 5:***

- Guide and crosshead bearing rod surfaces in contact with crosshead.
- Worm teeth and gear teeth.
- Seal cartridge (Item #29).
- Worm gear in contact with lower bearing (Item #21).
- Thrust washer (Item #23).
- Surface in contact with lower bearing (Item #21).