

# Transmitter

## BiT – Barksdale Intelligent Transmitter *Series H455X, 455X, 452X*

### Features

- ▶ Lightweight, compact and all-welded rugged stainless steel construction
- ▶ Thin-film & diffused silicon sensors for high accuracy
- ▶ Optional HART® communication protocol with diagnostics & field calibration, reducing maintenance time and cost; and 10:1 turndown ratio for rangeability, maintaining high accuracy and allowing one part for multiple pressure ranges
- ▶ High accuracy down to 0.1% FSO, LHR
- ▶ cULus, ATEX, IECEx and Single Seal certifications
- ▶ Explosion proof enclosure with IP66 / IP67 and NEMA 4X, 7 & 9 ratings
- ▶ CE, CRN, NORSOK and NACE compliant and Superior EMI, ESD and RFI protection
- ▶ Factory sealed, environment friendly, halogen free wires and cable

### Applications

- ▶ Production Control Systems
- ▶ Chemical Injection Systems
- ▶ Oil & gas pipelines
- ▶ Petrochemical plants
- ▶ Refineries
- ▶ Coal and oil fired power plants
- ▶ Hydraulic Power Units
- ▶ Gas transfers for fuel systems



### General Specifications\*

<b>Accuracy (LH &amp; R): at 75°F, Typical</b>	±0.10% of Calibrated FSO (Option [-A1]) ±0.25% of Calibrated FSO (Standard) ±0.50% of Calibrated FSO (Vacuum only [-23])	<b>Dynamic Response Time:</b> H455X: 455X & 452X:	<70 milliseconds <50 milliseconds
<b>Temperature Shift:</b>	Zero & Span: 0.0125% Per °F over the compensated temperature range	<b>Sensors:</b>	Thin-Film (15k to 30k psi ranges) Diffused Silicon (Vacuum to 10k psi ranges)
<b>Long Term Stability:</b>	±0.2% FSO/year of calibration curve	<b>Enclosure:</b>	All welded 300 series stainless steel. IP67 and NEMA 4X rated. 316L Stainless Steel (optional)
<b>Typical Life Cycle:</b>	100 million cycles	<b>Wetted Parts:</b>	
<b>Proof Pressure:</b>	2X range for up to 7500 psi models 1.5X range for 7500 - 30000 psi models	<b>Sensor:</b>	17-4 PH Stainless steel (15k-30k psi) 316L Stainless steel (up to 10k psi) Inconel (optional: up to 10k psi)
<b>Input:</b> H455X: 455X*: 452X*:	Excitation voltage: 9 to 30 VDC Excitation voltage: 9 to 30 VDC Excitation voltage: 12 to 30 VDC * (SELV, PELV), Class 2 Power Supply	<b>Fitting:</b>	17-4 PH Stainless steel (all ranges) 316L Stainless steel and 718 Inconel (optional: up to 10k psi)
<b>Supply Current:</b>		<b>Media</b>	
H455 & 455:	20 mA max.	<b>General:</b>	Gas, vapor, liquid and viscous fluids [-Z17]
452:	20 mA max.	<b>Corrosive and Acidic:</b> (up to 10,000 psi)	718 Inconel wetted material, NACE [-NC]; and 316L Stainless Steel, NACE [-SS]
<b>Output:</b> H455X:	Output: 4-20 mA with HART® Protocol Full Scale Span: 16 mA ±1% Zero output: 4 mA ±1%	<b>Pressure Connection:</b>	13 available options. Refer to product configurator for available connections and ranges.
455X:	Output: 4-20 mA Full Scale Span: 16 mA ±1% Zero output: 4 mA ± 1%	<b>Electrical Connection:</b>	3 conductors for voltage output series and 2 conductors for current output series, 18 AWG, 80" (2 m) long with integral strain relief and case ground (standard). Jacketed cable (optional)
452X:	Output: 1-5 VDC Full Scale Span: 4.0 VDC ± 1% Zero output: 1.0 VDC ± 1%	<b>Temperature Ranges:</b>	
		<b>Operating (Ambient):</b>	-40 to +185 °F (-40 to +85 °C)
		<b>Compensated:</b>	0 to +165 °F (-18 to +74 °C)
		<b>Media:</b>	-40 to +257 °F (-40 to +125 °C)
		<b>Storage:</b>	-40 to +185 °F (-40 to +85 °C)
		<b>Vibration:</b>	15 g's, 10-2K Hz, MIL-STD 202, Method 204, Cond. A
		<b>Shock:</b>	50 g's, 11 mS, MIL-STD 202 Method 213, Cond. G.

\* See product configurator for additional options.

# BiT – Barksdale Intelligent Transmitter *Series H455X, 455X, 452X*

## General Specifications\* cont.

<b>Approvals: (pending)</b> cULus:	cULus approved as telemetering equipment for use in hazardous locations (UL File E146589, WYMV, WYMV7) as follows: Class I, Div. 1, Groups A, B, C & D Class II, Div. 1, Groups E, F & G
<b>Single Seal:</b>	CSA C22.2 No. 61010-1 Certified ANSI/ISA 12.27.01 Certified (for ranges up to 10,000 PSI)
<b>ATEX/IECEx:</b>	CE 0081 CE II 2 G D, Ex db IIC xx C (T6) Gb, Ex tb IIIC Db IP67, IP 66 -40° C ≤ Tamb ≤ +85° C, xxxxx ATEX xxxxxxx, IECEx XX 18.xxxxx
<b>HART® Protocol:</b>	HART® 7.6
Turndown Ratio:	10:1 (Full scale output rangeability)
Analog Output Calibration:	Adjustable zero and span of 4-20mA. Full scale range must be ≥ (calibrated span / 10)
Sensor Trim:	Sensor zero and full scale trim
Diagnostics:	Transmitter failure indicated by off-scale analog signals to alarm the user

<b>Compliances:</b>	CE, CRN, NACE/NORSOK (316L SS or 718 Inconel wetted material)
<b>Electromagnetic Capability (EMC) (Pending)</b> IEC/EN 55011:	Emission & radiated emission for class A limits
IEC/EN 61000-4-2:	Electrostatic discharge (ESD) test - contact discharge +/-4 kV, Air discharge +/-8 kV
IEC/EN 61000-4-3:	Radiated RF, EM field immunity 80mhz-1ghz, 3v/M
IEC/EN 61000-4-4: H455X:	EFT (Burst) Test, +/-2 kV
455X & 452X:	EFT (Burst) Test, +/-1 kV
IEC/EN 61000-4-5: H455X:	Surge Test, +/-1kV on lines, +/-2kV between line and earth ground
455X & 452X:	Surge test not applicable; Class 2 power supply used at input of the device
IEC/EN 61000-4-6:	RF Immunity, 150 kHz – 80 MHz, 3V
<b>Weight:</b>	16 Ounces (453 grams)
<b>Warranty:</b>	1 year warranty

\* See product configurator for additional options.

## Wiring Code

TABLE 1. FREE LEAD WIRE CONNECTIONS

MODEL NO.	RED	BLACK	GREEN	WHITE
H455X	+ EXCITATION	- EXCITATION	EARTH GROUND	NOT INCLUDED
455X	+ EXCITATION	- EXCITATION	EARTH GROUND	NOT INCLUDED
452X	+ EXCITATION	- EXCITATION	EARTH GROUND	VOLTAGE OUTPUT

TABLE 2. JACKETED CABLE WIRE CONNECTIONS (-J Option)

MODEL NO.	RED	BLACK	GREEN	WHITE
H455X	+ EXCITATION	- EXCITATION	EARTH GROUND	NOT INCLUDED
455X	+ EXCITATION	- EXCITATION	EARTH GROUND	NOT INCLUDED
452X	+ EXCITATION	- EXCITATION	EARTH GROUND	VOLTAGE OUTPUT

CONFIGURATION WITH HART

**Point to Point**

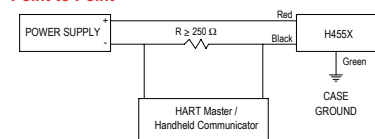

**Multi Drop**

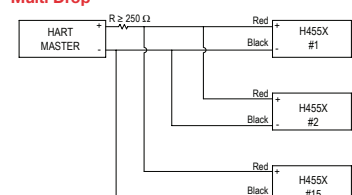

# Transmitter

## BiT – Barksdale Intelligent Transmitter *Series H455X, 455X, 452X*

### Technical Drawings

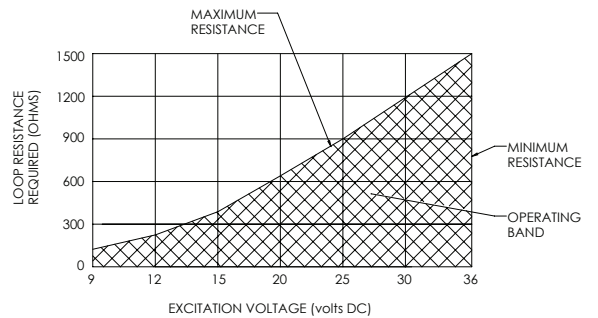
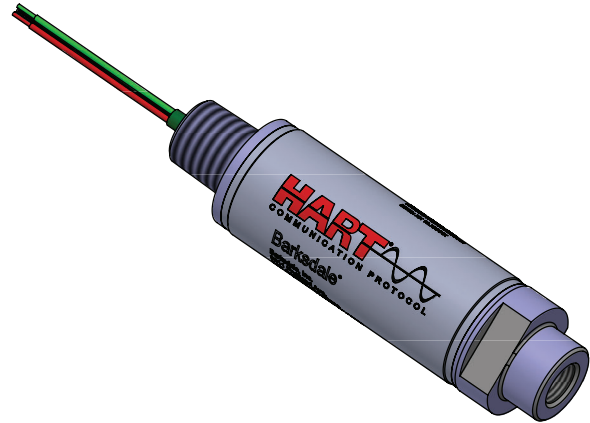
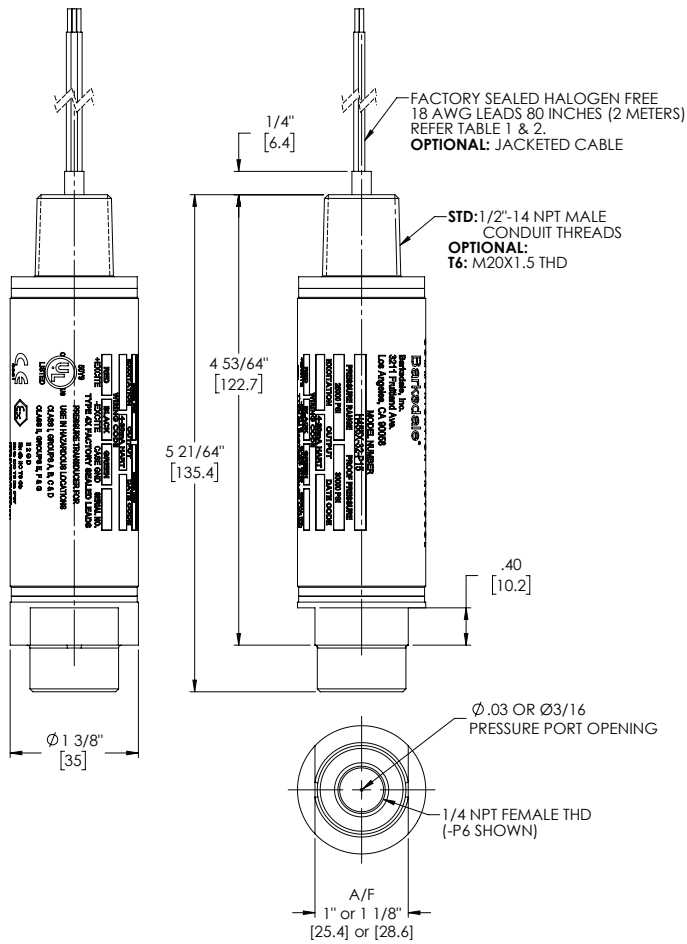

### Process Connections

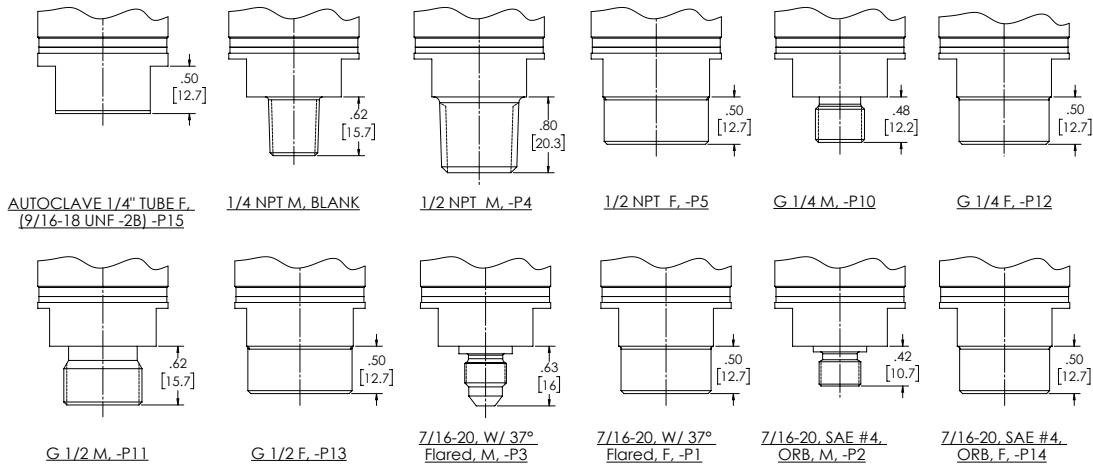

**Barksdale®**  
CONTROL PRODUCTS

CRANE Barksdale, Inc./Barksdale GmbH  
A Subsidiary of Crane Co.

# BiT – Barksdale Intelligent Transmitter *Series H455X, 455X, 452X*

## Product Configurator

Example: **H455X T6 -29 BA -P15 -Z17-A1-Z123**

### Base Model

H455X	4 - 20 mA Output with HART® Comm. Protocol
455X	4 - 20 mA Output
452X	1-5 VDC Output

### Electrical Connection

Blank	1/2"-14 NPT Male conduit
T6	M20 x 1.5 Male conduit

### Pressure Range

-23 <sup>*4</sup>	0-29.9" of Hg	0 to -1 Bar
-01	0-15 psi	0-1 Bar
-21	0-30 psi	0-2 Bar
-03	0-50 psi	0-3 Bar
-22	0-60 psi	0-4 Bar
-04	0-100 psi	0-7 Bar
-05	0-150 psi	0-10 Bar
-06	0-200 psi	0-15 Bar
-07	0-300 psi	0-20 Bar
-08 <sup>1</sup>	0-500 psi	0-40 Bar
-10 <sup>1</sup>	0-1,000 psi	0-70 Bar
-11 <sup>1</sup>	0-1,500 psi	0-100 Bar
-12 <sup>1</sup>	0-2,000 psi	0-150 Bar
-13 <sup>1</sup>	0-3,000 psi	0-200 Bar
-14 <sup>1</sup>	0-4,000 psi	0-300 Bar
-15 <sup>1</sup>	0-5,000 psi	0-350 Bar
-16 <sup>1</sup>	0-6,000 psi	0-400 Bar
-17 <sup>1</sup>	0-7,500 psi	0-500 Bar
-18 <sup>1</sup>	0-10,000 psi	0-700 Bar
-29 <sup>1,2</sup>	0-15,000 psi	0-1,000 Bar
-30 <sup>1,2</sup>	0-20,000 psi	0-1,400 Bar
-31 <sup>1,2</sup>	0-22,000 psi	0-1,500 Bar
-32 <sup>1,2</sup>	0-25,000 psi	0-1,700 Bar
-33 <sup>1,2</sup>	0-30,000 psi	0-2,000 Bar

\* Vacuum

### Pressure Unit & Type

Blank	PSI - Gauge pressure (standard)
A	PSI - Absolute pressure (Not applicable with "-23" range)
B	Bar - Gauge Pressure
BA	Bar - Absolute Pressure (ranges start from -1 Bar) (Not applicable with "-23" range)

### Options

-ZVxx	Custom voltage output (Available on 452X only). Up to 10VDC. Consult Factory.
-Z17 <sup>1</sup>	For high pressure models with larger orifice; without pressure surge protector
-SS <sup>3</sup>	316L Stainless steel wetted material (NACE)
-A1	Accuracy BFSL 0.1% FSO, typical (LHR) at 75°F
-ZXXY	Special pressure ranges XX - significant digits Y - number of trailing zeros Example: 130 psi calibration: add -Z131
-J	Jacketed cable
-WXXX	Additional length of free leads/cable (in inches)

### Process Connection

Blank <sup>3</sup>	1/4-18 NPT male (standard)
-P6 <sup>3</sup>	1/4" NPT female
-P4 <sup>3</sup>	1/2" NPT male
-P5 <sup>3</sup>	1/2" NPT female
-P10 <sup>3</sup>	G 1/4, washer seal, male
-P12 <sup>3</sup>	G 1/4, washer seal, female
-P11 <sup>3</sup>	G 1/2, washer seal, male
-P13 <sup>3</sup>	G 1/2, washer seal, female
-P3 <sup>3</sup>	7/16-20, with 37° flared, male
-P1 <sup>3</sup>	7/16-20, with 37° flared, female
-P2 <sup>3</sup>	7/16-20, SAE #4, ORB, male
-P14 <sup>3</sup>	7/16-20, SAE #4, ORB, female
-P15	HF4 Autoclave, 1/4" tube, female (9/16-18 UNF-28 THD)

### Notes

1. Pressure ranges indicated have built-in pressure surge protector. Add "-Z17" suffix for high pressure models with no snubber; for use with high viscosity media. With Z17 option, orifice diameter is 0.188" without Z17 option, (standard units) orifice diameter is 0.030"
2. 15,000 to 30,000 psi ranges available only with "-P15" Process Connection
3. Available up to 10,000 psi
4. No agency approval.

## Additional Documents and Accessories

Title	Reference Number
Installation and Maintenance Instructions	272439
HART Installation and Operation Manual	272438
Certificate of Compliance (Found on back of packing slip)	Use Document Title in purchase order. Only available at the time of order.
Certificate of Compliance (Signed document)	
Test Report	
Calibration Test Sheet	
Material Certification	
Paper Tag	
Metal Tag	



TABLE 1. FREE LEAD WIRE CONNECTIONS				
MODEL No.	RED	BLACK	GREEN	WHITE
H455X	+ EXCITATION	- EXCITATION	EARTH GROUND	NOT INCLUDED
455X	+ EXCITATION	- EXCITATION	EARTH GROUND	NOT INCLUDED
452X	+ EXCITATION	- EXCITATION	EARTH GROUND	VOLTAGE OUTPUT

TABLE 2. JACKETED CABLE WIRE CONNECTIONS (-J Option)				
MODEL No.	WHITE	BROWN	GREEN	YELLOW
H455X	+ EXCITATION	- EXCITATION	EARTH GROUND	NOT INCLUDED
455X	+ EXCITATION	- EXCITATION	EARTH GROUND	NOT INCLUDED
452X	+ EXCITATION	- EXCITATION	EARTH GROUND	VOLTAGE OUTPUT

ADDITIONAL SPECIFICATIONS	
CATEGORY	SPECIFICATIONS
LONG TERM STABILITY:	±0.2% FSO /yr OF CALIBRATION CURVE
TYPICAL LIFE CYCLE:	100 MILLION CYCLES
TEMPERATURE SHIFT:	ZERO & SPAN: : 0.0125% PER °F OVER THE COMPENSATED TEMPERATURE RANGE.
VIBRATION:	15 G'S, 10-2000 HZ, MIL-STD 202, METHOD 204
SHOCK:	50 g's, 11 ms, MIL-STD 202 METHOD 213, COND. G.
WEIGHT:	453 Grams

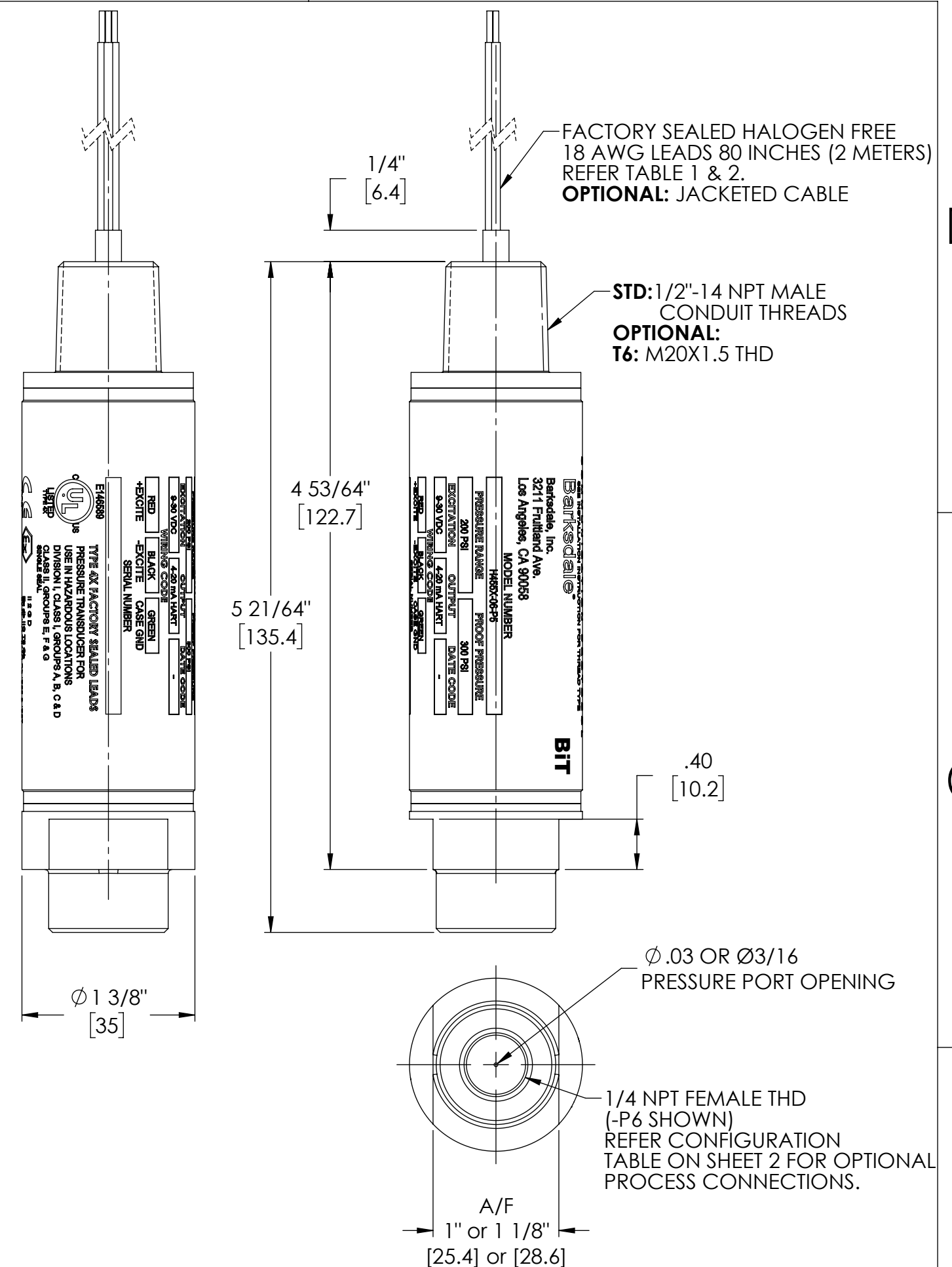

- 16. PRESSURE RANGES INDICATED HAVE BUILT-IN PRESSURE SURGE PROTECTOR. ADD "-Z17" SUFFIX FOR HIGH PRESSURE MODELS WITH NO SNUBBER FOR USE WITH HIGH VISCOSITY MEDIA.  
ORIFICE SIZE WITH -Z17: BLANK,-P6,-P4,-P5,-P12,-P13,-P1,-P14: Ø.188"[4.78]; -P11: Ø.125"[3.17], -P10,-P3,-P2: Ø.093"[2.36]; -P15: Ø.063"[1.60]  
ORIFICE SIZE WITHOUT -Z17: UP TO 10kPSI= Ø.030"[0.76], FOR -UL AND 15K TO 30kPSI=Ø.020"[0.5].
- 15. PART NUMBERS: ARE RATED IN PSIG. FOR RATING IN PSIA INSERT "-A" FOLLOWING THE PRESSURE RATING. (EXAMPLE: H455X-04-A IS RATED IN PSIA, H455X-04 IS RATED IN PSIG)

14. MATERIAL OF CONSTRUCTION:  
HOUSING, ELECTRICAL CONNECTION: 304 STAINLESS STEEL, OPTIONAL: 316L STAINLESS STEEL.

13. WETTED MATERIAL:  
SENSOR:  
STANDARD: THIN-FILM SENSOR, 17-4 PH STAINLESS STEEL (15k-30k PSI AND 10k PSI WITH -UL OPTION) MODELS  
STANDARD: DIFFUSED SILICON SENSOR, 316L STAINLESS STEEL (UP TO 10k PSI) MODELS  
FITTING (PROCESS CONNECTION):  
STANDARD: 17-4 PH STAINLESS STEEL (ALL RANGES)  
OPTIONAL: 316 & 316L STAINLESS STEEL (UP TO 10k PSI)

12. 450X SERIES EXPLOSION PROOF PRESSURE TRANSMITTERS ARE LISTED FOR USE IN HAZARDOUS LOCATIONS AS FOLLOWS:

**APPROVALS:**

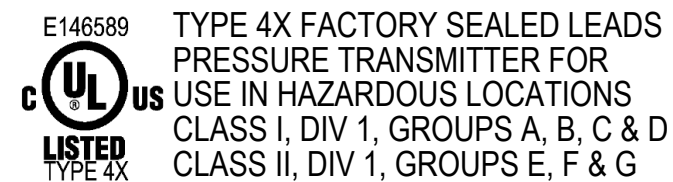
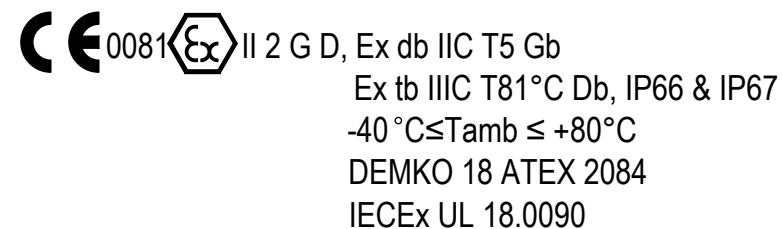

SINGLE SEAL APPROVAL PER ANSI/ISA 12.27.01 UP TO 10K PSI RANGES.  
COMPLIANCES: CE, CRN, NACE

11. THERMAL, ZERO AND SPAN EFFECT: ±0.0125% PER °F OVER THE COMPENSATED TEMPERATURE RANGE.

10. SPAN ACCURACY: ±1% FSO AT 75° F (24°C).

9. SPAN ADJUSTMENT (TURN DOWN): 10:1 (WITH HART OPTION)

8. ZERO BALANCE: ±1% FSO AT 75° F (24°C).

7. RESPONSE TIME: H455X: <70ms; 455X & 452X: <50ms.

6. COMPENSATED TEMPERATURE RANGE: 0 to +165°F (-18 to +74°C).  
STORAGE TEMPERATURE RANGE: -40 to +185°F (-40 to +85°C)  
MEDIA TEMPERATURE RANGE: -40 to +176°F (-40 to +80°C)  
OPERATING (AMBIENT) TEMPERATURE: -40 to +176°F (-40 to +80°C).

5. ACCURACY (LINEARITY, HYSTERESIS, REPEATABILITY): ±0.25% FSO AT 75° F.  
±0.10% FSO AT 75° F (OPTIONAL).  
±.5% FOR VACUUM ONLY [-23] TYP.

4. DIGITAL AMPLIFIER (CURRENT/VOLTAGE OUTPUT):  
H455X: 4 - 20 mA (WITH HART OPTION)  
455X: 4 - 20 mA  
452X: 1 - 5 VDC

3. EXCITATION VOLTAGE:  
H455X: 9 TO 30 VDC (WITH HART OPTION)  
455X: 9 TO 30 VDC (CLASS 2 POWER SUPPLY)  
452X: 12 TO 30 VDC (CLASS 2 POWER SUPPLY)

2. PROOF PRESSURE: 2X RANGE FOR UP TO 7500 PSI MODELS;  
1.5X RANGE FOR 7500 - 30000 PSI MODELS.

1. PRESSURE RANGE: REFER PRODUCT CONFIGURATOR ON PAGE 2.  
NOTES: UNLESS OTHERWISE SPECIFIED

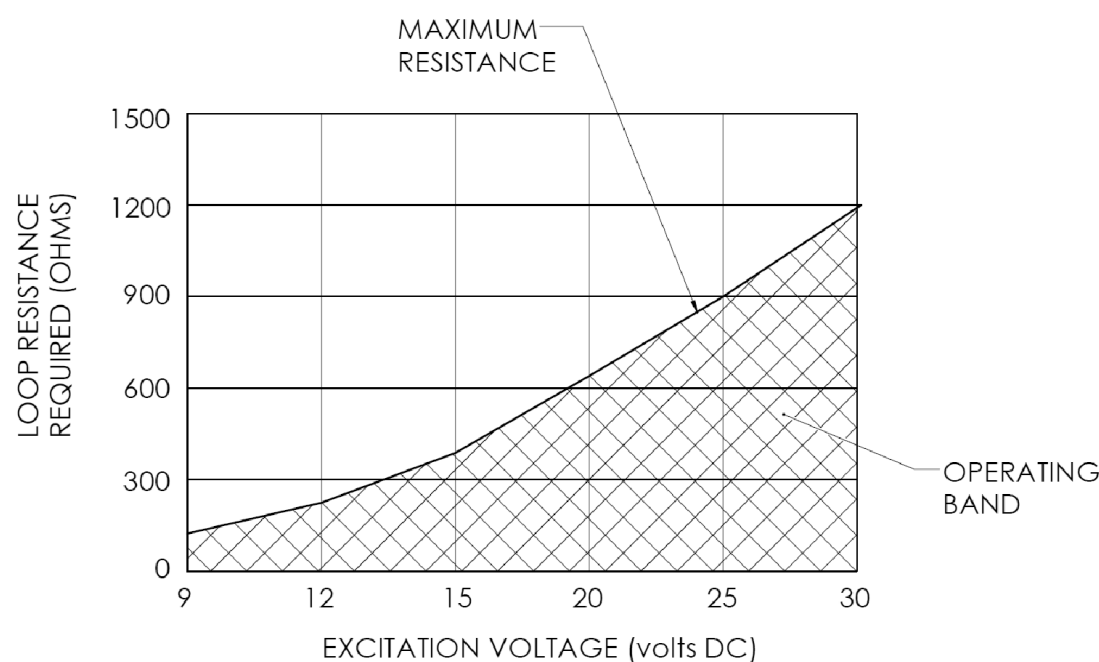

DRAWN PAVAN	DATE 05-16-2017	EXPLOSION PROOF BARKSDALE INTELLIGENT TRANSMITTER WITH OPTIONAL HART COMM PROTOCOL	NEXT ASSEMBLY 982211 982212 982213 982214	00011183	D	12-05-2018
CHECKED	DATE		00011144	C	11-01-2018	
APPROVED YONG K	DATE XX-XX-2017	UNLESS OTHERWISE SPECIFIED	REFERENCE DPM DPM-4202.034	00011075	B	09-11-2018
DIMENSIONAL TOLERANCES			DIST. <input type="checkbox"/> Gmh	00010982	A	07-24-2018
FRACTIONAL DECIMAL ANGULAR	±1/16 ±.010 ±5°	www.barksdale.com	WEIGHT	SCALE 1:1	DWG. C	REV. D
DIMENSIONS IN BRACKETS ARE IN MILLIMETERS			Los Angeles, CA 90058-0843 Ph: 323-589-6181 Fax: 323-583-6252	450X		SHEET 1 OF 2

# PRODUCT CONFIGURATOR

EXAMPLE: H455X T6 -29 BA -P6 -Z17-A1-Z801

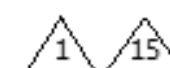

### BASE MODEL

<b>HART</b> COMMUNICATION PROTOCOL	4 - 20 mA Current Output with HART Comm. Protocol	H455X
	4 - 20 mA Digital Amplifier (Current Output)	455X
	1-5 VDC Digital Amplifier (Voltage Output)	452X

### ELECTRICAL CONNECTION

1/2"-14 NPT Male conduit	BLANK
M20 x 1.5 Male conduit	T6

PSI	BAR	PRESSURE RANGE
0-29.9" of Hg (Vac.)	0 to -1 Bar (Vac.)	-23
0-15 PSI	0-1 Bar	-01
0-30 PSI	0-2 Bar	-21
0-50 PSI	0-3 Bar	-03
0-60 PSI	0-4 Bar	-22
0-100 PSI	0-7 Bar	-04
0-150 PSI	0-10 Bar	-05
0-200 PSI	0-15 Bar	-06
0-300 PSI	0-20 Bar	-07
0-500 PSI	0-40 Bar	-08
0-1,000 PSI	0-70 Bar	-10
0-1,500 PSI	0-100 Bar	-11
0-2,000 PSI	0-150 Bar	-12
0-3,000 PSI	0-200 Bar	-13
0-4,000 PSI	0-300 Bar	-14
0-5,000 PSI	0-350 Bar	-15
0-6,000 PSI	0-400 Bar	-16
0-7,500 PSI	0-500 Bar	-17
0-10,000 PSI	0-700 Bar	-18
0-15,000 PSI	0-1,000 Bar	-29
0-20,000 PSI	0-1,400 Bar	-30
0-22,000 PSI	0-1,500 Bar	-31
0-25,000 PSI	0-1,700 Bar	-32
0-30,000 PSI	0-2,000 Bar	-33

### OPTIONS

-ZVxx	Custom Voltage Output (Available on 452X only) Up to 10VDC. Consult Factory.	
-Z17	Without pressure surge protector	16
-SC	All 316 Stainless Steel construction with 316L SS wetted material (NACE)	19
-SS	316L Stainless Steel wetted material (NACE)	19
-UL	cULus in addition to ATEX & IECEx approvals (-18 range code only)	22
-A1	Accuracy BFSL 0.1% FSO (LHR) at 75°F (Consult factory on vacuum [-23] models)	
-ZXXY	Special pressure ranges XX - significant digits Y - number of trailing zeros	
-Wxxx	Custom length of Free Leads (in inches)	18
-Jxxx	Jacketed Cable (in inches)	

### PROCESS CONNECTIONS

BLANK	1/4" NPT, Male	
- P6	1/4" NPT, Female	
- P4	1/2" NPT, Male	
- P5	1/2" NPT, Female	
- P10	G 1/4, washer seal, Male	
- P12	G 1/4, Washer seal, Female	
- P11	G 1/2, Washer seal, Male	
- P13	G 1/2, Washer seal, Female	
- P3	7/16-20, with 37° Flared, Male	
- P1	7/16-20, with 37° Flared, Female	
- P2	7/16-20, SAE #4, ORB, Male	
- P14	7/16-20, SAE #4, ORB, Female	
- P15	HF4 Autoclave, 1/4" Tube, Female (9/16-18 UNF-28 THD)	20 21

### PRESSURE UNIT & TYPE

BLANK	PSI - Gauge Pressure	
A	PSI - Absolute Pressure (Not applicable with "-23" range)	24
B	Bar - Gauge Pressure	
BA	Bar - Absolute Pressure (ranges start from -1 Bar) (Not applicable with "-23" range)	24

22 "UL" OPTION ONLY AVAILABLE FOR 10,000 PSI RANGE. NO cULus APPROVAL FOR 10K PSI RANGE WITHOUT -UL OPTION. cULus APPROVAL STANDARD FOR ALL OTHER RANGES. ATEX & IECEx APPROVALS STANDARD FOR ALL RANGES.

21 "-P15" AVAILABLE WITH ALL PRESSURE RANGES.

20 15k TO 30k PSI PRESSURE RANGES AVAILABLE ONLY WITH "-P15" PROCESS CONNECTION. MUST USE HIGH-PRESSURE MATING FITTING/TUBING CONNECTIONS RATED FOR 60,000 PSI OF HF4 TYPE.

19 AVAILABLE UP TO 10K PSI RANGE. -SS OPTION IS INCLUDED IN -SC OPTION. MATERIAL OF PROCESS CONNECTION IS 316L STAINLESS STEEL WITH -SC OPTION. NOT AVAILABLE WITH -UL OPTION.

18 STANDARD MODIFICATIONS: ADD IDENTIFIER TO P/N (EXAMPLE: H455X-01-W180 = STANDARD 0-15 PSI HART MODEL WITH 180 INCH LONG WIRES).

17. TYPE 4X ENCLOSURE ENVIROMENTAL RATING IP66 & IP67

24 ABSOLUTE RANGES AVAILABLE FOR UP TO 300 PSI MODELS.

- 23. IEC/EN 55011: CONDUCTED EMISSION AND RADIATED EMISSION FOR CLASS A LIMITS
- IEC/EN 61000-4-2: ELECTROSTATIC DISCHARGE (ESD) TEST - CONTACT DISCHARGE +/-4KV, AIR DISCHARGE +/-8KV
- IEC/EN 61000-4-3: RADIATED RF, EM FIELD IMMUNITY - 80MHZ-1GHZ, 3V/M
- IEC/EN 61000-4-4: H455X: EFT(BURST) TEST, +/-2KV  
455X/452X: EFT(BURST) TEST, +/-1KV
- IEC/EN 61000-4-5: H455X: SURGE TEST, +/-1KV BETWEEN LINE AND EARTH GND  
455X/452X: SURGE TEST NOT APPLICABLE; CLASS 2 POWER SUPPLY USED AT INPUT OF THE DEVICE.
- IEC/EN 61000-4-6: CONDUCTED RF IMMUNITY, 150KHZ-80MHZ, 3V

**Barksdale**  
CONTROL PRODUCTS  
CRANE Barksdale, Inc./Barksdale GmbH  
A Subsidiary of Crane Co.

www.barksdale.com  
Los Angeles, CA 90058-0843  
Ph: 323-589-6181 Fax: 323-583-6252

WEIGHT	SCALE	DWG.	REV.
	1:1	C	D
SHEET 2 OF 2			

# Barksdale®

## CONTROL PRODUCTS

**CRANE**

Barksdale, Inc./Barksdale GmbH  
A Subsidiary of Crane Co.

# BiT - Barksdale Intelligent Transmitter

## 450X, 450E & 450 Series



## Installation and Operational Manual



- ▶ High Performance thin-film sensor for high pressure models
- ▶ ATEX, IECEx, UL, CSA and Single Seal approvals for use in hazardous locations
- ▶ Lightweight and compact footprint, up to 55% smaller than competitors in its class with an all stainless-steel design
- ▶ Latest HART 7 communication protocol carries device diagnostics, field calibration and rangeability capabilities over the 2-wire 4-20mA output
- ▶ 10:1 turndown ratio (re-ranging) enabling remote span adjustability while maintaining accuracy and allowing one part number for multiple pressure ranges
- ▶ Highly accurate down to 0.1% FSO (LHR)
- ▶ Vacuum to 30,000 psi (24 standard ranges), custom ranges available
- ▶ Long term stability, reducing maintenance & calibration cost
- ▶ Multiple process & electrical connections to meet your application needs
- ▶ NACE and CE compliant with highly corrosion resistant material, environment friendly halogen free wires and superior EMI/RFI protection

**Barksdale, Inc.**  
3211 Fruitland Avenue,  
Los Angeles, CA 90058-0843  
U.S.A.  
Phone: (800) 835-1060  
Bulletin No. 272438-C  
[www.barksdale.com](http://www.barksdale.com)

## Contents

SAFETY INSTRUCTIONS AND WARNINGS .....	3
Legends: .....	3
1. Introduction .....	4
1.1 <i>Using this manual</i> .....	4
1.2 <i>Product Recycling/ Disposal</i> .....	4
2. Installation .....	5
2.1 <i>HART Transmitter Installation Flowchart:</i> .....	5
2.2 <i>Mounting:</i> .....	5
2.3 <i>Wiring and Power-up:</i> .....	6
3. Configuration and Diagnostics .....	8
3.1 <i>Device Variables – Review configuration data</i> .....	8
3.1.1 Primary Variables (PV) Measurement .....	9
3.1.2 Range Values and PV Status .....	9
3.1.3 Device Information .....	10
3.1.4 Loop Test .....	10
3.2 <i>Device Setup</i> .....	11
3.2.1 Set process variable units .....	12
3.2.2 Re-range .....	12
3.2.3 Damping .....	14
3.2.4 Loop Current Mode and Multi-drop communication .....	14
3.2.5 HART Setup .....	15
3.3 <i>Diagnostics – Device Status</i> .....	16
4. Operation and Maintenance .....	17
4.1 <i>Calibration for HART Transmitter</i> .....	17
4.2 <i>Calibration overview for BIT</i> .....	17
4.2.1 Zero Trim .....	17
4.2.2 Restore Factory Zero .....	18
5. Troubleshooting: .....	19
6. Product configurator – How to order .....	20
7. Appendix A: Installation and Maintenance Instructions (IMI) .....	20
8. Appendix B: Product Certifications & Downloads .....	20
9. Return Request / Inquiries .....	20



## SAFETY INSTRUCTIONS AND WARNINGS

⚠ Read this manual before working with the product. The contents must be thoroughly read and understood before installing, using or maintain this product. Misuse of this product may cause explosion and personal injury.

⚠ **450X Series** EXPLOSION PROOF pressure transmitters are listed for use in Hazardous Location (Classified)



Class I, Div. I, Groups A, B, C & D  
Class II, Div. I, Groups E, F & G.



II 2 G D,  
Ex, db IIC T5 Gb,  
Ex tb IIIC T81°C Db IP66 & IP67  
-40°C ≤ Tamb ≤ +80°C  
DEMKO 18 ATEX 2084  
IECEX UL 18.0090  
HART Protocol (Optional)

Consult Sales Drawing & EN/IEC 61000-4 for appropriate Electromagnetic Compatibility (EMC) requirements.

⚠ Temperature Range:  
Compensated: 0 to +165°F (-18 to +74°C)  
Storage: -40 to +185°F (-40 to +85°C)  
Media: -40 to +176°F (-40 to +80°C)  
Operating (ambient): -40 to +176°F (-40 to +80°C).

⚠ **455E Series** INTRINSIC SAFETY Pressure Transmitters are listed for use in Hazardous Location (Classified)  
USE WITH BARKSDALE CONTROL DRAWING #272471



Class I, Div. I, Groups A, B, C & D  
Class II, Div. I, Groups E, F & G  
Ex ia IIC T4 Ga  
Ex ia IIIC T135°C Da  
Class I, Zone 0, AEx ia IIC T4 Ga  
Zone 20, AEx ia IIIC T135°C Da  
FACTORY SEALED NEMA 4X ENCLOSURE



II 1 G D,  
Ex, ia IIC T4 Ga,  
Ex ia IIIC T135°C Da IP66 & IP67  
-40°C ≤ Tamb ≤ +80°C  
CML 19 ATEX 2240X  
IECEX CML 19.0066X

⚠ **450 Series** for Ordinary Locations (Non-Hazardous):  
For ordinary locations:



- ⚠ Prior to installation, check the wetted parts material for compatibility to the process media.
- ⚠ This product should be installed according to local standards and codes for that area.
- ⚠ This product does not have any field replaceable parts. Any replacement of components will invalidate third-party issued approvals and certifications, and may impair suitability for Class I, Div. I / Zone 0 locations.
- ⚠ Avoid contact with the exposed leads and terminals. High voltage that may be present on leads can cause electrical shock.
- ⚠ Properly tighten process connections before applying pressure.
- ⚠ Apply and maintain pressure within the limits of markings of the device.

## Legends:

BIT	Barksdale Intelligent Transmitter
HART	Highway Addressable Remote Transmitter
DCS	Distributed Control System
PLC	Programmable Logic Controller
PV	Primary Variable
DDL	Device Description
LRV	Lower Range Value
LSL	Lower Sensor Limit
URV	Upper Range Value
USL	Upper Sensor Limit
Xtr	Transfer
PC	Personal Computer
AWG	American Wire Gage

## 1. Introduction

### 1.1 Using this manual

The manual provides information on installation, configuration, operation and maintenance of the 450 & 450X series BIT Pressure Transmitter.

- **Installation** contains mechanical and electrical installation instructions.
- **Configuration** provides instruction on configuring the transmitter with a field communicator and Distributed Control System. Information on software functions and configuration parameters is also included.
- **Operation and Maintenance** contains operation and maintenance instructions.
- **Troubleshooting** provides troubleshooting techniques for the most common operating problems.
- **Appendix A: Installation & Maintenance Instructions**
- **Appendix B: Product Certifications**

### 1.2 Product Recycling/ Disposal

Recycling of equipment and packaging should be taken into consideration and disposed of in accordance with local and national legislation/regulations.

This product has Printed Circuit Board. So should be considered as e-waste and should be disposed accordingly.

## 2. Installation

Refer to IMI #272439 (450X Series) & #272441 (450 Series) for Installation & Maintenance Instructions and Product Specifications.

### 2.1 HART Transmitter Installation Flowchart:

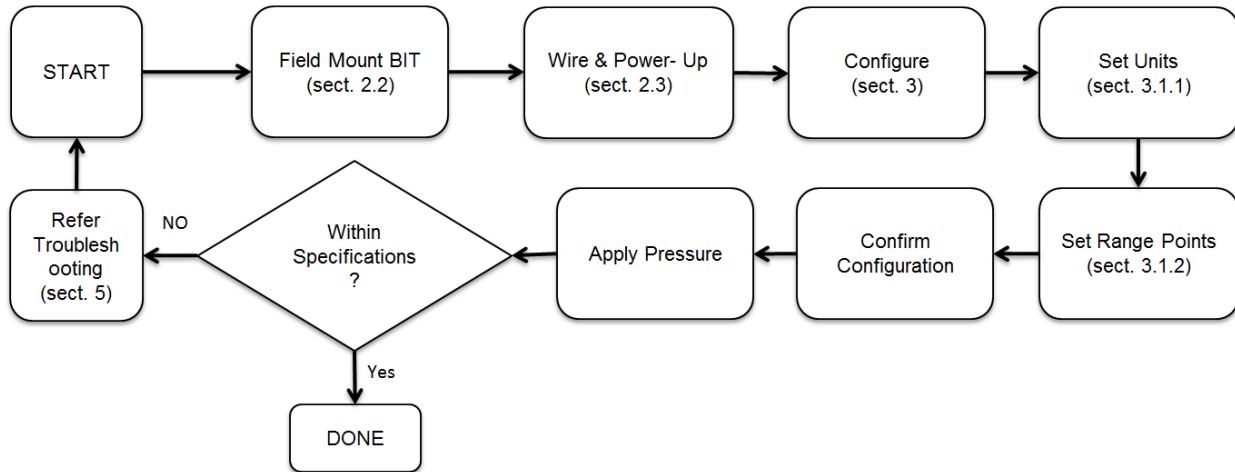

### 2.2 Mounting:

Always locate the product where shock, vibration and ambient temperature fluctuations are minimal. Do not mount in ambient temperature areas exceeding 85°C (for cULus installation) or 80 °C (for ATEX installation). Apply torque 125 to 150 lb.in to the flat available at the process connection of the transmitter. Refer below dimensional drawing while mounting of the unit.

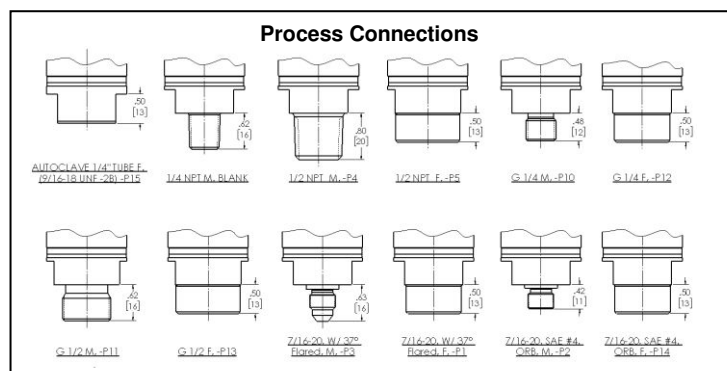
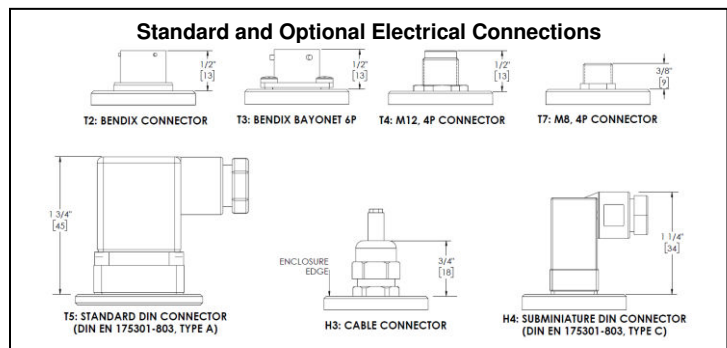
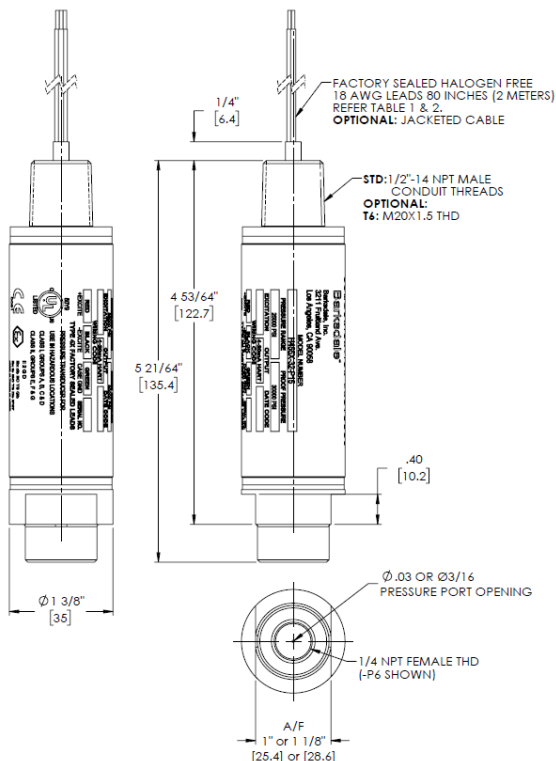

Figure 1: Dimensional Drawing

## 2.3 Wiring and Power-up:

Use quality low-capacitance twisted pair or shielded wire cable. Do not run wires next to power lines, electrical systems, motors, generators, or any other equipment which may generate a significant amount of electrical noise or magnetic fields. If shielded cable is used, ground only one side of the cable, typically to the negative side of the power supply.

As a general rule of thumb, if the cable length is less than 5000 ft., #24 AWG wire can be used. Any cable runs over 5000 ft. should use #20 AWG wiring. Customer can do the further wire connection to standard 18 AWG wire provided with unit.

### Wire Code for connections:

TABLE 1. FREE LEAD WIRES AND CONNECTOR PIN CONNECTIONS				
MODEL No.	RED/A/1	BLACK/B/2	GREEN/D/4	WHITE/C/3
H455	+ EXCITATION	- EXCITATION	EARTH GROUND	NOT INCLUDED
455	+ EXCITATION	- EXCITATION	EARTH GROUND	NOT INCLUDED
452	+ EXCITATION	- EXCITATION	EARTH GROUND	VOLTAGE OUTPUT

TABLE 2. JACKETED CABLE WIRE CONNECTIONS (-J Option)				
MODEL No.	WHITE	BROWN	GREEN	YELLOW
H455	+ EXCITATION	- EXCITATION	EARTH GROUND	NOT INCLUDED
455	+ EXCITATION	- EXCITATION	EARTH GROUND	NOT INCLUDED
452	+ EXCITATION	- EXCITATION	EARTH GROUND	VOLTAGE OUTPUT

To set up a current loop capable of reliable HART communication, several items are needed:

- HART capable/enable device
- DC regulated power supply, set to 24 V or 9 to 30 VDC range.
- Minimum 250 ohm load resistor
- Quality twisted pair or shielded wire
- HART Master (PC or Handheld Field Communicator)

The unit should be attached to the power supply with load resistor in series as shown in the picture below to create the current loop. A current meter can be placed anywhere on the loop to measure the loop current. A voltmeter can also be used to measure the current by measuring the voltage across the 250 ohm in series as shown in the picture below.



The two HART signal wires can either encapsulate the load resistor or the HART unit under test, as shown in the picture below. Since HART allows for two masters (Primary and Secondary), the two masters can be attached at the same points.

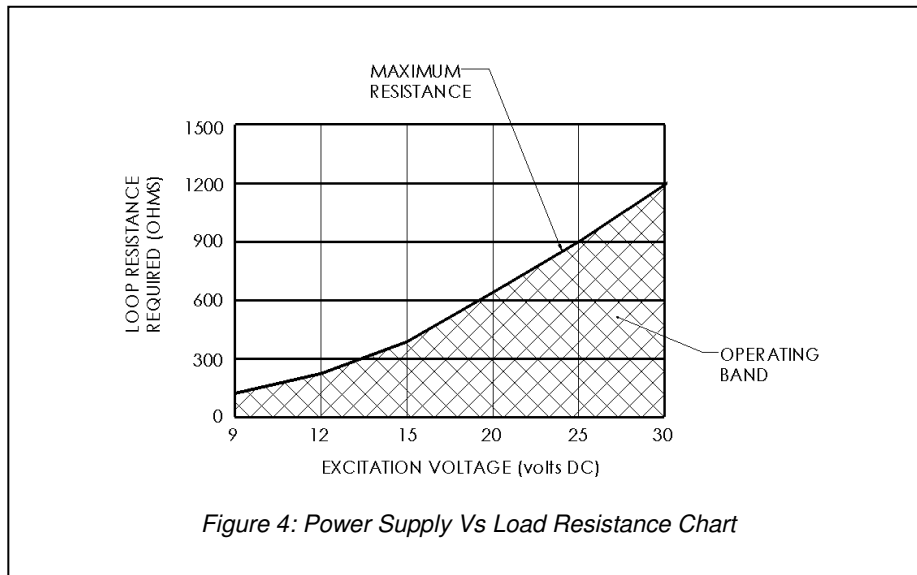
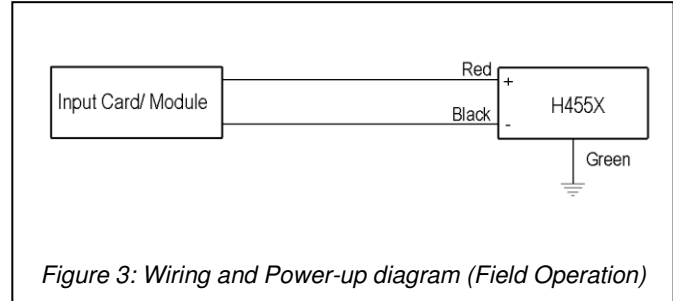
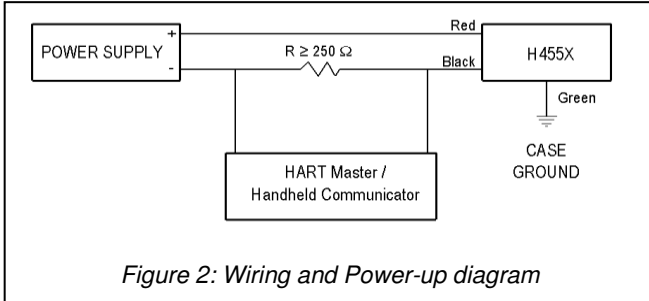

Note: Communication requires a minimum loop resistance of 250 ohms.

### 3. Configuration and Diagnostics

This section provides instruction on configuring the BIT. Information on software functions and configuration parameters is included.

The instructions can be performed using either a compatible Field communicator or a Distributed Control System. The Enhanced Device Descriptor files are required to be imported before performing any action. When using a Field Communicator, any configuration change made must be sent to the transmitter by using the Send key. Similarly, configuration changes made using a Distributed Control System are implemented when the 'Apply' button is selected.

⚠ Whenever sending or requesting data that would disrupt the loop or change the output of the transmitter, set the process application loop to manual. The user interface on either a field communicator or a DCS will prompt you to set the loop to manual when necessary. Acknowledging this prompt does not set the loop to manual. The prompt is only a reminder; set the loop to manual as a separate operation.

#### 3.1 Device Variables – Review configuration data

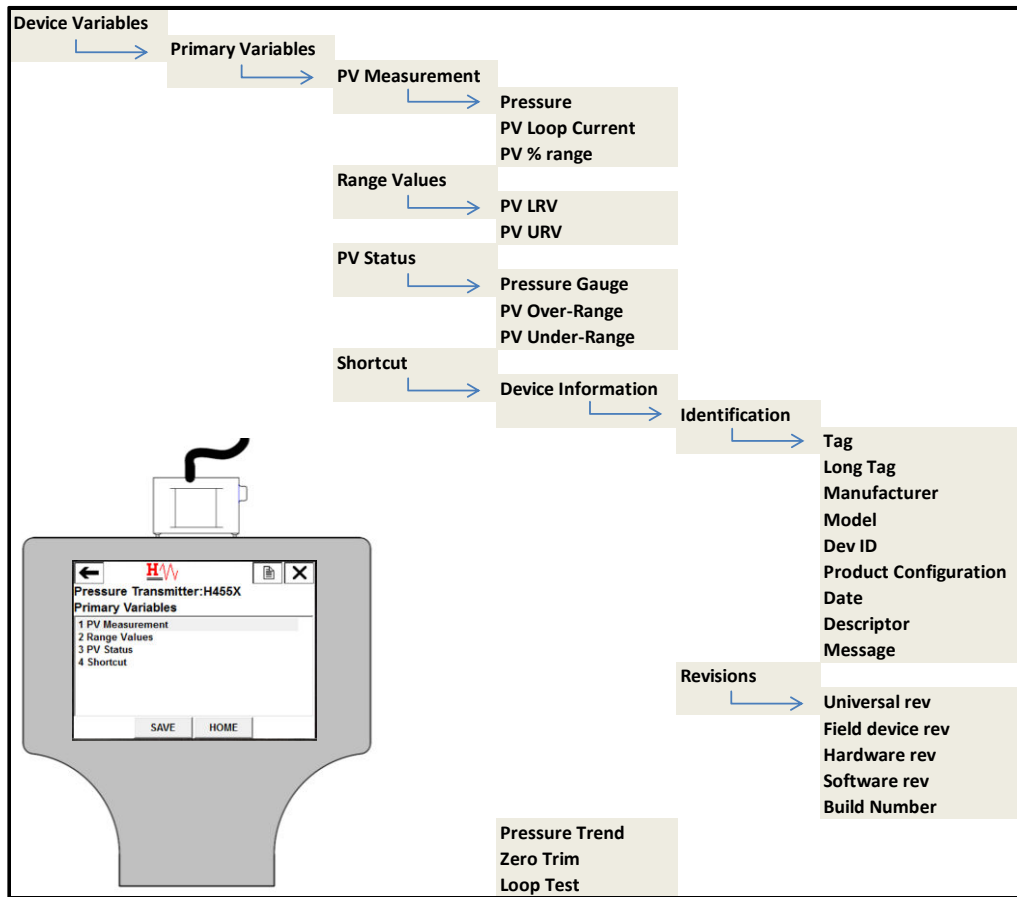

The device variables provide transmitter output, range values, PV status, device identification and device revisions. This is a read-only section meant to give an overview of the process and the device. An exception is the shortcut provided to perform the essential procedures including Zero Trimming and Loop Test.

Before placing the transmitter into operation, review the transmitter configuration data and the digital output parameters to ensure the transmitter is operating properly.

### 3.1.1 Primary Variables (PV) Measurement

The PV measurement provides transmitter output, and is continuously updated. The pressure reading is provided in the selected engineering units along with percent of range and analog output or the PV loop current.

#### Host Interface - Field Communicator and DCS

The path to reach the PV measurement is as follows:

**Device Variables → Primary Variables → PV Measurement**

You may also refer to the Menu Tree above. PV measurement menu displays the following variables:

- Pressure
- Percent of Range
- PV Loop Current - Analog Output

### 3.1.2 Range Values and PV Status

The pressure reading in both engineering units and percent of range will continue to track the pressures outside of the defined range from the lower to the upper range limit.

#### Host Interface - Field Communicator and DCS

The path to reach the Range Values and PV Status are as follows:

**Device Variables → Primary Variables → Range Values**

**Device Variables → Primary Variables → PV Status**

You may also refer to the Menu Tree above. Range Values menu displays the following variables:

- PV LRV – Lower Range Value
- PV URV – Upper Range Value

The transmitter automatically and continuously performs self-diagnostic routines. If the self-diagnostic routines detect a failure, the transmitter reports the failure under PV Status and drives the output to configured alarm values.

- PV Over-range: The transmitter will set this alert if the applied pressure goes beyond the Upper Range Value. This will also latch the transmitter output to 20mA.
- PV Under-range: The transmitter will set this alert if the applied pressure goes below the Lower Range Value. This will also latch the transmitter output to 4mA.

### 3.1.3 Device Information

The Device Information provides important information regarding Device Identification and Revision numbers.

#### Host Interface - Field Communicator and DCS

The path to reach the Device Information is as follows:

**Device Variables → Primary Variables → Shortcut → Device Information**

You may also refer to the Menu Tree above. Device information menu displays the following variables:

- Identification
  - Tag
  - Long Tag
  - Manufacturer
  - Model
  - Device ID
  - Product Configuration
  - Date
  - Descriptor
  - Message
- Revisions
  - Universal Rev
  - Field Device Rev
  - Hardware Rev
  - Software Rev
  - Build Number

### 3.1.4 Loop Test

The Loop Test feature is designed to verify proper loop wiring and transmitter output, and should only be performed after the installation of the transmitter.

#### Host Interface - Field Communicator and DCS

The path to reach the enhanced method “Loop Test” are as follows:

**Device Variables → Primary Variables → Shortcut → Loop Test**

**Device Setup → Guided Setup → Loop Test**

You may also refer to the Menu Tree above. The enhanced method will guide you through the following procedure:

- Connect a reference meter to the transmitter by shunting transmitter power through the meter at some point in the loop.
- Select Next after the control loop is set to manual.
  - ⚠ Whenever sending or requesting data that would disrupt the loop or change the output of the transmitter, set the process application loop to manual. The user interface on either a field communicator or a DCS will prompt you to set the loop to manual when necessary. Acknowledging this prompt does not set the loop to manual. The prompt is only a reminder; set the loop to manual as a separate operation.
- Select a discrete milliamp level for the transmitter to output. The available options are:
  - 4mA
  - 20mA
  - Other – manually input a desired value between 4 and 20mA range
- Check the reference meter installed in the test loop to verify that it displays the commanded output value.
- If the values match, the transmitter and the loop are configured and functioning properly.



- If the values do not match, the current meter may be attached to the wrong loop, there may be a fault in the wiring, the transmitter may require re-ranging, or the reference meter may be malfunctioning.

After completing the test procedure, the method returns to the loop test screen to select another output value or to end loop testing.

- Select End and select Next to end loop testing.
- Select Next to acknowledge the loop can be returned to automatic control.
- Select Finish acknowledging the method is complete.

### 3.2 Device Setup

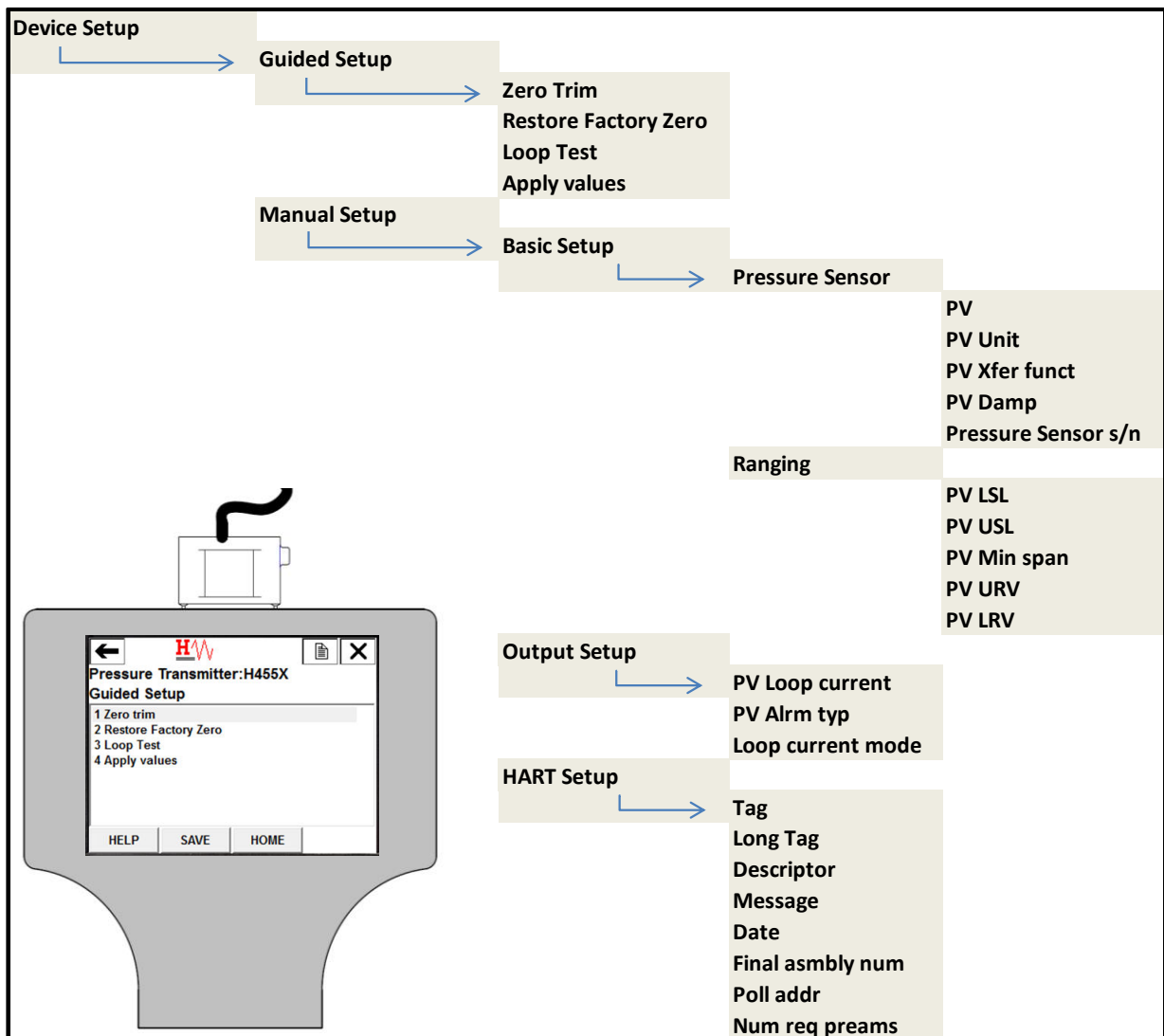

### 3.2.1 Set process variable units

The PV unit command sets the process variable units to allow you to monitor your process using the appropriate units of measure.

#### Host Interface - Field Communicator and DCS

The path to reach the PV unit is as follows:

**Device Setup → Manual Setup → Basic Setup → Pressure Sensor → PV Unit**

You may also refer to the Menu Tree above. Select from the following engineering units:

- inH<sub>2</sub>O
- bar
- psi
- KPa

### 3.2.2 Re-range

The Range Values command sets the 4 and 20 mA points and digital lower (LRV) and upper (URV) range values. In practice, you may reset the transmitter range values as often as necessary to reflect changing process conditions. Changing the lower or upper range point results in similar changes to the span.

Use one of the methods below to re-range the transmitter. Each method is unique; examine all options closely before deciding which method works best for your process.

- Re-range with a Field Communicator only
- Re-range with a pressure input source and a Field Communicator
- Re-range with a DCS only
- Re-range with a pressure input source and a DCS

#### 3.2.2.1 Re-range with a Field Communicator only

The easiest and most popular way to re-range is to use the Field Communicator. This method changes the values of the analog 4 to 20 mA points independently without a pressure input.

The path to reach the PV URV and LRV are as follows:

**Device Setup → Manual Setup → Basic Setup → Ranging → PV URV**

**Device Setup → Manual Setup → Basic Setup → Ranging → PV LRV**

You may also refer to the Menu Tree above. Use the keypad to enter lower and upper range values.

NOTE: The upper range value has to be less than the upper sensor limit or the PV USL. Similarly, the lower range value has to be greater than the lower sensor limit or the PV LSL.

#### 3.2.2.2 Re-range with a pressure input source and a Field Communicator

Re-ranging using the Field Communicator and a pressure source or process pressure is a way of re-ranging the transmitter when specific 4 and 20 mA points are unknown.

Use the enhanced method “Apply values” to achieve this functionality. This method will guide you step by step through the procedure of re-ranging. The path to reach the “Apply values” method is as follows:

**Device Setup → Guided Setup → Apply values**

The enhanced method will guide you through the following procedure:

- Select Next after the control loop is set to manual.
- From the Apply values menu, follow the online instructions to configure upper and lower range values.

NOTE: The span is maintained when the 4 mA point is set. The span changes when the 20 mA point is set. The lower range value cannot be set to a value that causes the upper range value to exceed the upper sensor limit.

- Select Exit to leave the Apply values screen.
- Select Next to acknowledge the loop can be returned to automatic control.
- Select Finish and acknowledge the method is complete.

### 3.2.2.3 Re-range with a DCS only

This method changes the values of the analog 4 to 20 mA points independently without a pressure input.

The path to reach the PV URV and LRV are as follows:

**Device Setup → Manual Setup → Basic Setup → Ranging → PV URV**  
**Device Setup → Manual Setup → Basic Setup → Ranging → PV LRV**

Enter the PV LRV and the PV URV in the fields provided under the Ranging group box. Select Apply.

NOTE: The upper range value has to be less than the upper sensor limit or the PV USL. Similarly, the lower range value has to be greater than the lower sensor limit or the PV LSL.

### 3.2.2.4 Re-range with a pressure input source and a DCS

Use the enhanced method “Apply values” to achieve this functionality. This method will guide you step by step through the procedure of re-ranging. The path to reach the “Apply values” method is as follows:

**Device Setup → Guided Setup → Apply values**

The enhanced method will guide you through the following procedure:

- Select Next after the control loop is set to manual.
- From the Apply values menu, follow the online instructions to configure upper and lower range values.

NOTE: The span is maintained when the 4 mA point is set. The span changes when the 20 mA point is set. The lower range value cannot be set to a value that causes the upper range value to exceed the upper sensor limit.

- Select Exit to leave the Apply values screen.
- Select Next to acknowledge the loop can be returned to automatic control.
- Select Finish and acknowledge the method is complete.

### 3.2.3 Damping

The Damp command introduces a delay in processing which increases the response time of the transmitter; smoothing variations in output readings caused by rapid input changes. Based on the necessary response time, signal stability and other requirements of the loop dynamics of the system, the damp is determined by the transmitter.

#### Host Interface - Field Communicator and DCS

The path to reach the PV Damp value is as follows:

**Device Setup → Manual Setup → Basic Setup → Pressure Sensor → PV Damp**

You may also refer to the Menu Tree above. The transmitter has a fixed damping value of 0.05 seconds and is not user-selectable.

### 3.2.4 Loop Current Mode and Multi-drop communication

The Loop Current Mode indicates whether the loop current is active or fixed i.e. the device is in multi-drop mode.

#### Host Interface - Field Communicator and DCS

The path to reach the Loop Current Mode is as follows:

**Device Setup → Manual Setup → Output Setup → Loop current mode**

You may also refer to the Menu Tree above. The Loop current will reflect the Process measurement as long as it is enabled. The Loop current mode is set to 'enable' at the factory, which allows operation in the standard point-to-point manner with a 4-20mA output signal.

Multi-dropping transmitters refers to the connection of several transmitters to a single communications transmission line. Communication between the host and the transmitters takes place digitally with the analog output of the transmitters deactivated. Up to 15 transmitters can be connected on a single twisted pair of wires. Each transmitter is identified by a unique address (1-15) in this mode.

The Figure below shows a typical multi-drop network.

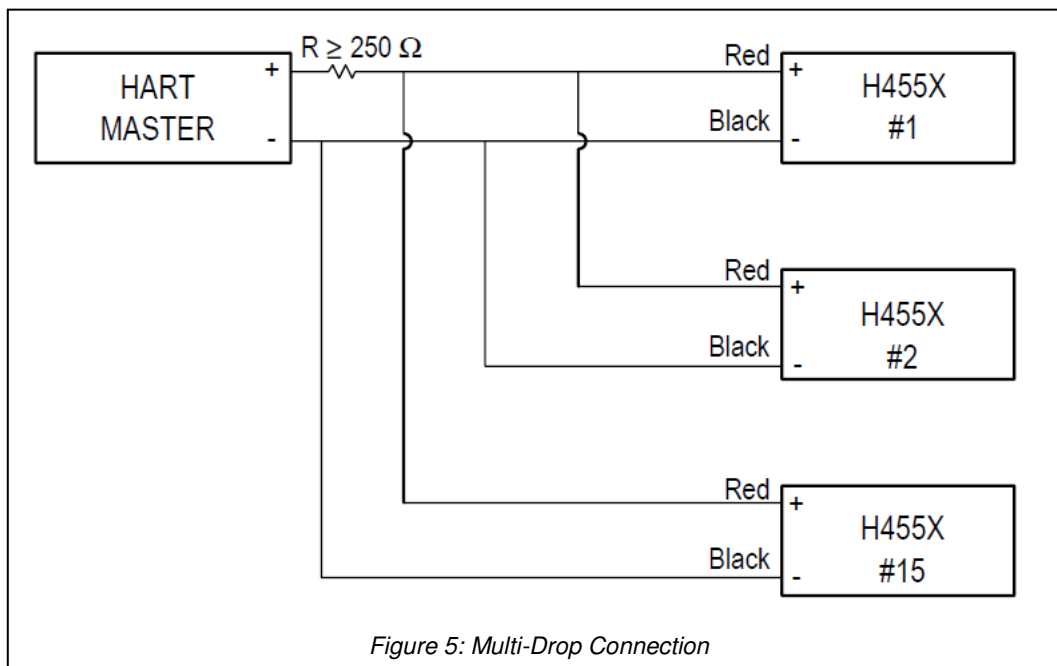

Figure 5: Multi-Drop Connection



The H455X is set to address zero at the factory. To activate multi-drop communication, the transmitter address must be changed to a number from 1 to 15.

This change will have the following affects:

- Disables the loop current mode that deactivates the 4-20mA analog output, sending it to 5mA.
- Disables the latching of analog output to 4mA in case of a PV under-range status and to 20mA in case of a PV over-range status.
- The self-diagnostic routine still remains active, thus continuing the alert reporting as per the PV measurement.
- Failure signals in multi-dropped transmitters are communicated through the HART messages.

#### 3.2.4.1 Changing a transmitter address

To activate multi-drop communication, the transmitter poll address must be assigned a number from 1 to 15, and each transmitter in a multi-dropped loop must have a **unique** poll address.

 **Note:** Verify the address of all the multi-dropped transmitters and ensure each transmitter has a unique poll address.

#### Host Interface - Field Communicator and DCS

The path to reach the Poll Address is as follows:

**Device Setup → Manual Setup → HART setup → Poll Address**

You may also refer to the menu tree above. To communicate with a multi-dropped transmitter, configure the Field Communicator or DCS to poll for a non-zero address. Please refer to documentation of the system you have.

#### 3.2.5 HART Setup

The HART Setup menu provides the configuration of the Device Identification parameters.

#### Host Interface - Field Communicator and DCS

The path to reach the HART Setup is as follows:

**Device Setup → Manual Setup → HART Setup**

You may also refer to the Menu Tree above. HART setup menu displays the following variables:

- Tag
- Long Tag
- Descriptor
- Message
- Date
- Final Assembly Number
- Poll Address
- Number of Request Preambles

### 3.3 Diagnostics – Device Status

The user can access all the Device Status and Extended device status under this menu.

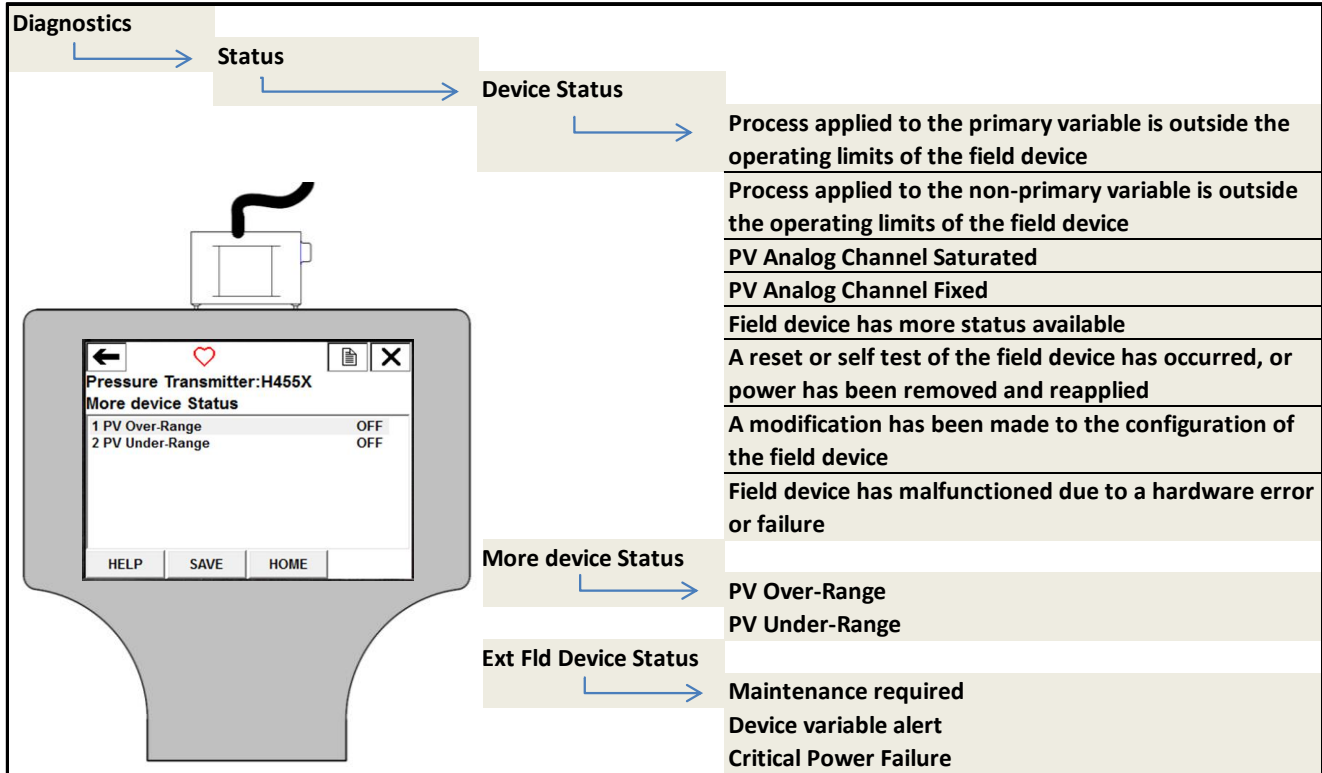

## 4. Operation and Maintenance

This section contains information on operation and maintenance of the Barksdale Intelligent Transmitter.

### 4.1 Calibration for HART Transmitter

Calibrating a transmitter may include the following procedures:

Re-range: Sets the 4 and 20 mA points at required pressures.

Sensor Trim: Adjusts the position of the factory characterization curve to optimize performance over a specified pressure range, or to adjust for mounting effects.

Analog Output Trim: Adjusts the analog output to match the plant standard or the control loop.

Trim and re-range functions differ significantly. Re-ranging sets analog output to the selected upper and lower range points and can be done with or without an applied pressure. Re-ranging does not change the factory settings. Sensor trimming requires an accurate pressure input and adds additional compensation that adjusts the position of the factory characterization curve to optimize performance over a specific pressure range.

**Note** Sensor trimming adjusts the position of the factory characterization curve. It is possible to degrade performance of the transmitter if the trim is done improperly or with inaccurate equipment.

### 4.2 Calibration overview for BIT

Re-range (Refer [section 3.2.2](#))  
Zero Trim  
Restore Factory Zero

#### 4.2.1 Zero Trim

**Note:** The transmitter must be within 5% of the span away from zero (for zero-based spans) in order to calibrate with zero trim function.

This method will calibrate the sensor input as the new zero input reference.

#### Host Interface - Field Communicator and DCS

The path to reach the Zero Trim is as follows:

#### Device Setup → Guided Setup → Zero trim

The enhanced method will guide you through the following procedure:

- Press OK after the control loop is set to manual.
- Apply zero pressure within the 5% of the span away from zero
- Follow the screen menu
- Press OK to acknowledge the loop can be returned to automatic control.

You may also refer to the Menu Tree in Section 3 – Configuration and Diagnostics

#### **4.2.2 Restore Factory Zero**

Restore factory zero is used to restore the transmitter to the default factory calibration settings.

##### **Host Interface - Field Communicator and DCS**

The path to reach the Zero Trim is as follows:

##### **Device Setup → Guided Setup → Restore Factory Zero**

The enhanced method will guide you through the following procedure:

- Press Ok after the control loop is set to manual.
- Transmitter will automatically set to factory settings
- Press Ok to acknowledge the loop can be returned to automatic control.

You may also refer to the Menu Tree in Section 3 – Configuration and Diagnostics.



## 5. Troubleshooting:

This section provides summarized maintenance and troubleshooting suggestions for the most common operating problems.

If you suspect malfunction despite the absence of any diagnostic messages on the Field Communicator display, follow the procedures described here to verify that transmitter hardware and process connections are in good working order.

Error	Cause
Output current reading is zero	Verify that the signal connections are powered
	Check the power cables for reversed polarity
	Verify terminal voltage is 9 to 30 VDC
Device not communicating with hand held communicator	Check that the output is between 4 and 20 mA or the saturation levels
	Verify terminal voltage is 9 to 30 VDC
	Check DC power to transmitter – maximum AC noise must be low
	Check loop resistance, 250 $\Omega$ minimum (PS voltage -transmitter voltage/loop current)
	Have Field Communicator poll for all addresses
Output current reading is low or high	Check the applied pressure
	Verify 4 and 20 mA range points
	Verify if 4–20 mA output trim is required
Analog Output does not change with respect to input Pressure	Check test equipment
	Check impulse piping or manifold for blockage
	Make sure the transmitter is not in Multi-drop mode
	Verify applied pressure is between the 4 and 20 mA set points
Pressure variable reading on HART communicator is low or high	Make sure the transmitter is not in loop test mode
	Check test equipment (verify accuracy)
	Check impulse piping for blockage or low fill in wet leg
	Check that the transmitter is correctly calibrated
Pressure variable reading on HART communicator is erratic	Verify pressure calculations for application
	Check application for faulty equipment in pressure line
Output current reading is erratic	Check that the transmitter does not react directly to the equipment on / off
	Check that the power source of the transmitter has adequate voltage and current
	Check for external electrical interference
	Check that the transmitter is properly grounded

## 6. Product configurator – How to order

Refer to configurator table on sales drawing or datasheet to configure the product.

- 450X Series: <https://www.barksdale.com/en/products/datasheet/351/series-450x/>
- 450 Series: <https://www.barksdale.com/en/products/datasheet/463/series-450/>
- 455E Series: Place Holder

Online product configurator and RFQ

- e-Configurator: <https://configurator.barksdale.com/>

## 7. Appendix A: Installation and Maintenance Instructions (IMI)

- 450X Series: <https://www.barksdale.com/en/products/datasheet/351/series-450x/>
- 450 Series: <https://www.barksdale.com/en/products/datasheet/463/series-450/>
- 455E Series: Place Holder

## 8. Appendix B: Product Certifications & Downloads

- 450X Series: <https://www.barksdale.com/en/products/datasheet/351/series-450x/>
- 450 Series: <https://www.barksdale.com/en/products/datasheet/463/series-450/>
- 455E Series: Place Holder

HART Foundation Certificate & DD:

<https://fieldcommgroup.org/registered-products/099a070e-1fb2-e811-8153-e0071b66aea1>

## 9. Return Request / Inquiries

Direct all warranty and repair requests/inquiries to Barksdale, Inc. Customer Service Department.

Call 323-589-6181, FAX: 323-589-3463

Before returning any product(s) to Barksdale, you must obtain a returned merchandise authorization from our customer service department (in order to avoid processing delays).

For warranty returns, please have the following information available BEFORE contacting Barksdale:

1. P.O. number under which the product was PURCHASED.
2. Model number of the product under warranty.
3. Repair instructions and/or specific problems you are having with the product.
4. Application information. Copyright 2018 Barksdale, Inc.

Represented by:



Zimco Instrumentation Inc.  
11141 15 Street NE, Calgary, AB, T3K 0Z5, Canada Phone: 403-253-8320  
Email: [info@zimco.ca](mailto:info@zimco.ca)  
Website: [www.zimco.ca](http://www.zimco.ca)

