



QTS

Quest-Tec Solutions
The New Standard of Level



MAGNE-TRACTM
LEVEL INDICATORS

Guided Level Radar Measurement

FMP40

Smart Transmitter for Level Measurement in Bulk Solids & Liquids and Interface Measurement in Liquids

- Measuring Range:
 - Up to 4 m / 13 ft (Rod probe, Coax probe)
 - Up to 35m / 114 ft (Rope probe)
- Temperature: -40°F to 302°F / -40°C to 150°C
- Pressure: 580 psi / -1...40 bar
- Dielectric constant:
 - 1.6 (Rod probe, Rope probe)
 - 1.4 (Coax probe)
- Probes:
 - Rod probe
 - Coax probe
 - Rope probe
- Output: HART®, PROFIBUS, Foundation Fieldbus



FMP40 LEVEL MEASUREMENT

Continuous level measurement of powdery to granular bulk solids e.g. plastic granulate and liquids.

- Measurement independent of density or bulk weight, conductivity, dielectric constant, temperature and dust e.g. during pneumatic filling
- Measurement is also possible in the event of foam or if the surface is very turbulent.
- The HART with 4 to 20 mA analog, PROFIBUS PA and FOUNDATION Fieldbus protocols are available for system integration.
- Application in safety related systems (overspill protection) with requirements for functional safety up to SIL 2 in accordance with IEC 61508/IEC 61511-1.
- WHG approval
- Remote mount up to 20'

FMP45

Smart Transmitter for Level Measurement in Liquids and Interface Measurement in Liquids

- Measuring Range:
 - Up to 4 m / 13 ft (Rod probe, Coax probe)
 - Up to 35m / 114 ft (Rope probe)
- Temperature: -328°F to 752°F / -200°C to 400°C
- Pressure: 5800 psi / -1...400 bar
- Dielectric constant:
 - 1.6 (Rod probe, Rope probe)
 - 1.4 (Coax probe)
- Probes:
 - Rod probe
 - Coax probe
 - Rope probe



Magne-Trac™ GUIDED WAVE COMBINATION GAGE



Used for redundant measurement

FMP45 LEVEL MEASUREMENT

Continuous level measurement of liquids. For highest of pressures and/or temperatures

- Temperature range: -328°F to 752°F / -200°C to 400°C
- Pressure range: 5800 psi / -1 ... 400 bar
- With second safety compartment feed though
- Rod and coax probes up to 4 m (157"), rope probes up to 35 m (1378") measuring range

The following interfaces are available for system integration:

- HART (standard) with 4 to 20 mA analog
- PROFIBUS PA
- FOUNDATION Fieldbus
- Remote mount up to 20'

MAGNE-TRAC™ LEVEL INDICATORS

Magnetic Level Gages

Quest-Tec Solutions is a leading supplier of magnetic level indicators, as well as traditional sight glasses and conductivity type remote level indicators for water indication in steam service. This wide range of products for level indication allows Quest-Tec Solutions the option of providing the best technology for nearly any level application.

The Magne-Trac™ level indicator is easy to install, low maintenance, and easy to view. Accessories include point level switches and transmitters to provide integration into plant control systems.

PRINCIPLE OF OPERATION

There are three major components of a Magne-Trac™ liquid level indicator: *Chamber, Float and Indicator*.

Magne-Trac™ Chamber: The chamber may be constructed of any non-magnetic material, including austenitic stainless steel, alloys such as Carpenter 20, and plastics. The chamber is typically mounted to the side of the vessel, with an inlet and outlet that will allow liquid level in the chamber to match the liquid level in the vessel in the same manner that traditional sight glasses work. Magne-Trac™ chambers are constructed in full compliance to ASME 31.1 and 31.3, and utilize flange end closures for float access.

Magne-Trac™ Float: Standard floats are constructed of thin wall, deep drawn 316 Stainless Steel or Titanium. Optional materials are available. Each float is custom engineered for a specific application and operating process variables. The float houses a magnet array, designed to project a magnetic field through the chamber and to an externally mounted indicator assembly. Variables considered in the construction of a float are dependent on the temperature, pressure and liquid density, as well as material compatibilities.

Magne-Trac™ Indicator: The standard indicator consists of anodized aluminum housing, rotating flags, and a clear cover. The flags are uniquely constructed of high temperature molded nylon. The standard UV stable Yellow/Black colors are molded into the flags. The non-corrosive nature of the material eliminates problems often encountered with corrosion associated with the aluminum flag/stainless steel pins most commonly supplied in the market. Magne-Trac™ indicators are constructed with a UV, scratch resistant polycarbonate window as standard, eliminating nuisance breakage of glass and allowing a high integrity fit. The flags are a wide 1.4" to enhance viewing. Each flag is assembled around a high temperature rare earth magnet assembly that ensures a latching action to eliminate false indication due to vibration.

At Quest-Tec Solutions, we have built our business on a readiness to adapt to specific customer requirements in terms of custom materials, fabrications and delivery requirements. The standard configurations and materials described above are by no means the limits of our capacity to supply.

FEATURES

- Innovative Flag Design Maximizes Magnetic Field
- Wide Flags for Enhanced Indicator View
- Impact Resistant Polycarbonate Indicator Window
- Corrosion Resistant Moving Parts
- Wide Variety of Materials
- Fabricated to ASME 31.1/31.3 Standards

SAMPLE SPECIFICATIONS

Magnetic Level Indicators shall be constructed of a non-magnetic material. Floats shall be deep drawn, spherical end, with a 360° magnet array. Indicators shall be housed in anodized aluminum. Flags shall be injection molded Amodel, 1.4" in width. Flag color shall be Yellow (liquid) and Black (vapor). The indicator face shall be UV and scratch resistant polycarbonate. End closures for float access shall be flanged.



MAGNE-TRAC™ TRANSMITTERS AND SWITCHES

Liquid Level Transmitter

MTLT-5000 Magnetostrictive

The MTLT-5000 is based upon the magnetostrictive principle. The sensing tube contains a wire which is pulsed at fixed time intervals. The interaction of the current pulse with the magnetic field created by the magnetic float causes a torsion stress wave to be induced in the wire. This torsion propagates along the wire at a known velocity, from the position of the magnetic float and toward both ends of the wire. The microprocessor-based electronics measure the elapsed time between the start and return pulses and convert it into a 4-20 mA DC output which is proportional to the level being measured.

FEATURES

- Designed to mount externally to the Magne-Trac™
- No maintenance required
- Multidrop HART Communications
- FM Approved Explosion Proof/IS
- NEMA 4X/7 enclosure
- Modular design
- Adjustable output damping
- Up to .001" resolution
- 2-wire loop powered
- RFI/EMI protection
- Offers a 4/20 mA 2-wire loop powered circuit for continuous level measurement
- Available in lengths up to 300 inches
- Process temperature range: -30°F to 400°F.
- The Non-Contact design ensures no wear to the sensing element, thus requiring no maintenance or recalibration



Reed Switch Transmitter

MTLT-2000

The sensor is a network of Reed Switches and resistors contained in a heavy wall stainless steel pipe. The sensor is mounted parallel with the chamber. As the float rises or falls it is closing Reed Switches, therefore changing the resistance proportionally to the level. The transmitter takes the change in resistance from the sensor, conditions it and transmits a 4-20 mA 2-wire signal. The transmitter is field rangeable to provide a full scale output over any portion of the span.

Level Switches

The switches are non-mercury. The bias magnet design latches the switch maintaining the contact after the level continues to rise or fall. The switches are fully adjustable and non-invasive. Switch points can be changed easily without any interruption to the visual indication or process.

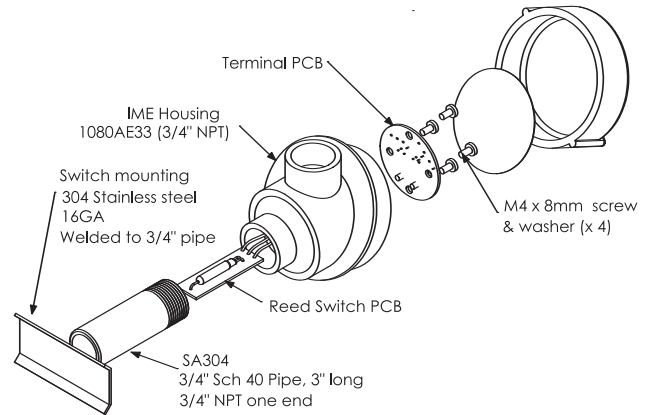

MTLS-3A

Max Volts240 VDC
Max Current3.0 AMPS
Max Power100 VA
Dead Band0.50 Inch
Max Temp600°F
Min Temp-40°F
ContactsSPDT
Elec. Class, Class 1 Div 1
Groups B, C, D

MTLS-5A

Max Volts125/250 VAC
Max Current5.0 AMPS
Max Power1200 VA
Dead Band0.50 Inch
Max Temp260°F
Min Temp-40°F
ContactsSPDT
Elec. Class, Class 1 Div 1
Groups B, C, D

Options

Indicators

Single Tracker

- Extra Large Indicator
- 1.40" Wide x 1.5" long
- Bright Yellow (other colors available)
- Dual Magnetic Coupling

Wide Flag

- 1.40" Wide
- 180 degree rotation
- Yellow-liquid, Black-vapor (Other colors available.)

Offshore

Insulation

- High Temperature
- Cryogenic with non-frost extension

Drum Level Indicator

- Meets ASME Boiler Code (PG60) for water remote level indicators on Boiler Drum

OTHER PRODUCTS FROM QUEST-TEC

Flash-Trac Transmitter

**Two Readings –
Local Indication and a 4-20 mA Signal – in One Device!**



- Patent Pending
- Bright, flashing LEDs give clear indication of level
- Loop-powered; no additional power required for indication
- 4-20 mA transmitter output
- Non-invasive; clamps parallel to chamber
- Intrinsically safe design
- No moving parts gives high reliability
- Operating temperature: -40°F to 200°F

The Flash-Trac Level Transmitter and LED indicator combines a reed switch based transmitter with a unique flashing LED level indication in an intrinsically safe loop-powered design.

Maverick Series

In-Tank Liquid Level Transmitter



- Microprocessor based
- Modular design
- High accuracy and repeatability
- Two channel output
- Multi-drop HART communication
- Retrofit existing displacers
- Stand-alone devices in tank
- Foundation Fieldbus
- 24 VDC, 2-wire loop (IS)
- Explosion-proof and/or intrinsically safe (model dependent)
- No maintenance required
- $\pm 2.7^\circ\text{F}$ ($\pm 1.5^\circ\text{C}$) accuracy on temperature output
- Rigid and flexible sensors to 480"
- Removable sensing element
- RTD option



Maverick Series Model MR sensors offer you unsurpassed flexibility to meet most process application conditions.

Up to two 4-20 mA loops are available for analog indication of level, interface and temperature. HART communication allows the Maverick Series sensor to indicate and display all three measurement variables simultaneously. The Maverick Series analog sensor can incorporate an RTD for spot temperature measurement of your process.

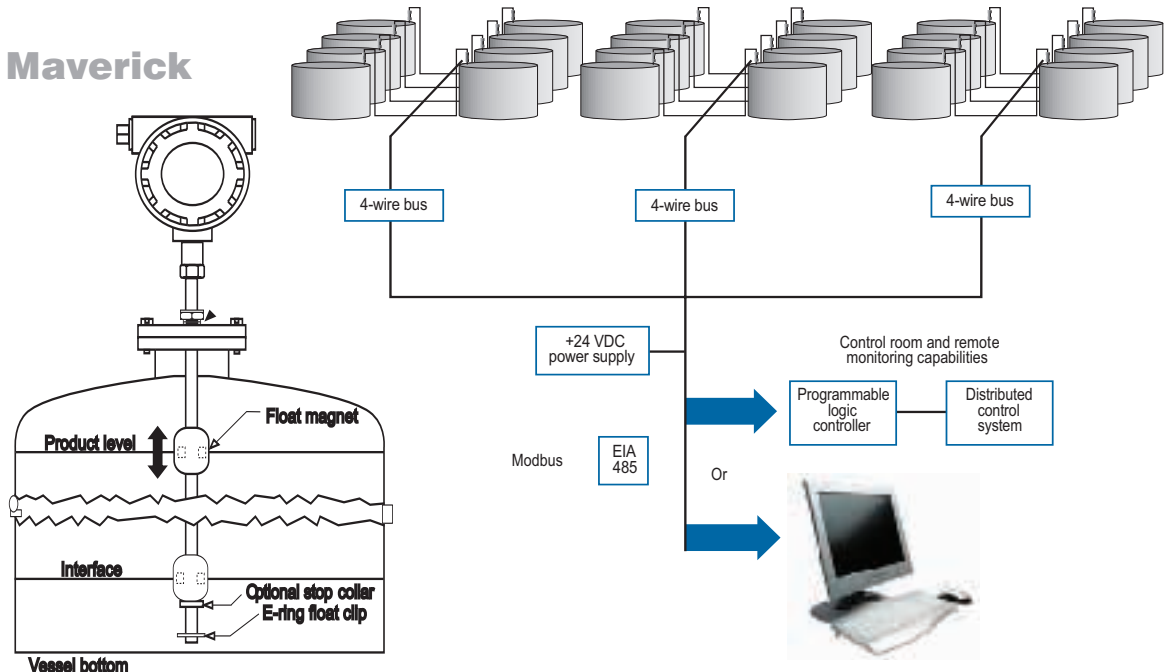

Specifying MAGNE-TRAC™ Model Number

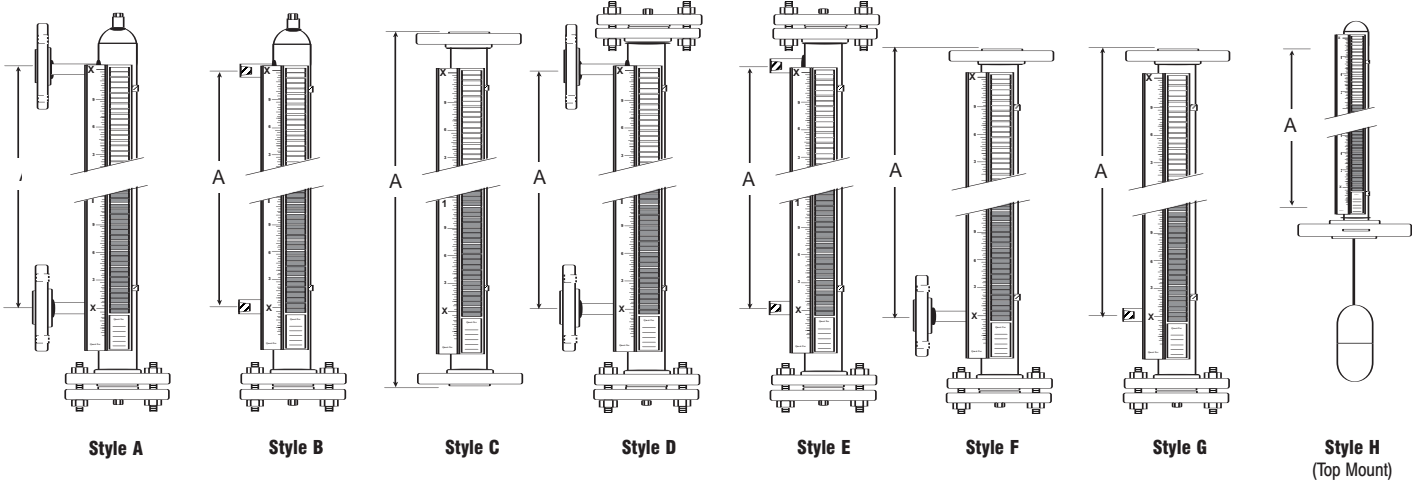

MT										
Magne-Trac™	Material	Style	Conn. Size	Flange Class	Specific Grav.	Max. Press	Max. Temp.	Ind. Range	Ind. Style	Options

4S = 304 SS
 4C = 304 SS/CS
 6S = 316 SS
 6C = 316 SS/CS
 A2 = Alloy 20
 MN = Monel
 T = Titanium
 HC = Hastelloy
 CP = CPVC
 CS = Customer Spec.

Material can be almost any non-magnetic type.

03 = 3/8"
 04 = 1/2"
 06 = 3/4"
 08 = 1"
 10 = 1 1/4"
 12 = 1 1/2"
 16 = 2"
 20 = 2 1/2"

01 = 150#
 03 = 300#
 04 = 400#
 06 = 600#
 09 = 900#
 15 = 1500#
 25 = 2500#

All styles use a flange for end closure.

These parameters must be based on Maximum Operating Conditions and are the basis for float construction.

Note Dimension "A" if different

WF = Wide Flag
 ST = Follower

Chamber

WN = Weld Neck Flanges
 SL = Stub End/Lap Joint Flanges
 RJ = Ring Joint Flanges
 BW = All Butt Weld Construction

Scale/Indicator

MS = Metric Scale
 PS = Percentage Scale
 NS = Negative Scale
 SS = Custom Scale (specify)
 AS = 3 1/2" Wide Acrylic Scale
 PI = Polycarbonate (Max 250°F)
 FE = Non Frost Extension
 DI = Dual Indication (ST/SST only)
 IF = Interface Indication
 AR = Arrow Pointers
 IL = Illuminator
 IG = Indicator Guard

Temp Control

CI = Cryogenic Insulation w/ Frost Extension
 HB = High Temp Insulation Blanket
 EH = Electrical Heat Tracing
 FP = Freeze Protection (Electrical)
 ST = Steam Traced Valves
 GV = Gate Valves (specify type)
 VD = Vent & Drain Valves
Testing/Material
 NM = NACE MRO175
 NDE = 100% Nondestructive Testing (Dye Penetration, X-ray)

ISO 9001: 2000



13960 S. Wayside
 Houston, TX 77048
 Toll Free: 866.240.9906
 Tel: 281.240.0440
 Fax: 281.240.2440

Visit our website at:
www.QTSLevel.com

Contact us by email:
sales@QTSLevel.com