

Quest-Tec Solutions
The New Standard of Level

Level Gage and Level Switch
**HRSG Drums, Boilers, Heaters,
De-Aerators, Condensers**

Direct and Indirect Per PG60.1

LEVEL-TRAC & STEAM-TRAC
STEAM/CONDENSATE LEVEL
SYSTEMS

Turbine Water Induction Prevention

Direct and Indirect Per PG60.1

Overview

All normally operating steam turbines carry the inherent risk of water ingress. Small amounts of condensate can enter from any connection to the turbine, sometimes arising rapidly from the condensation of steam. This almost always results in catastrophic damage to the turbine, even in low pressure situations. Human operators are rarely able to recognize and prevent these problems as quickly as they occur. Therefore, automatic turbine water induction prevention (TWIP) systems must be used to safeguard turbines from this danger. They save significant costs through quick detection and prevention of water ingress into the steam turbine.

The Quest-Tec Solution

Quest-Tec offers a range of products to safeguard your system with TWIP. Safe plant operation begins with a 12 Probe Level-Trac LT-220 system installed on the boiler drum with high alarms and high trips set and continues with the LT-310 on Heater Drains, Superheat and Reheat Main Drains, and on Drip Pots downstream of Attemperators. This will monitor all potential areas for turbine water induction and automatically detect it. Our products fulfill the ASME's recommendations

for safe steam turbine operation made in the TDP-1-2006 Standard.

The LT-310 Series' works on the same principles as the high integrity LT-210 Series Resistivity and is selected where 1-6 probe channels are required. A single probe can be utilized to provide a control signal or several can be paired and validated against each other where greater reliability is demanded. It offers a sensitivity that is reliably able to detect condensate down to 0.5 mS/cm^2 instantly.

The circuits are in a continual state of test, with any faults reported through relay contacts and a visual indicator mounted on the front panel. The system can be set up such that no failed individual probe or component can cause a false signal, thereby always maintaining the critical functionality of the probes.

Standard Features

Quest-Tec includes a number of standard features in all TWIP products to ensure easy operation and maintenance. Standard features include: Alarms & Validated Tripping Relays, Normally Energized or De-energized Relays, Time Delays, Sensitivities Settings, LED flash. All are easily set with solder pads

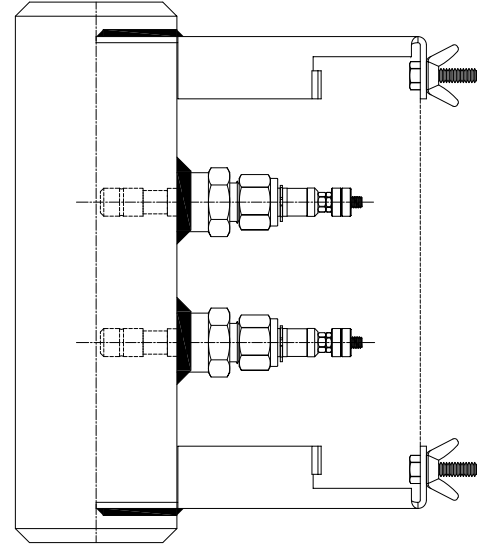

in the field or by Quest-Tec before delivery. Products also include an electronics integrity test button that tests the entire system's operation.

TWIP applications are standard in many respects, but engineered pressure parts are typically custom built to customer specifications to minimize installation costs.

Trust Quest-tec's high quality equipment to provide TWIP so you can operate your steam turbines safely and efficiently.

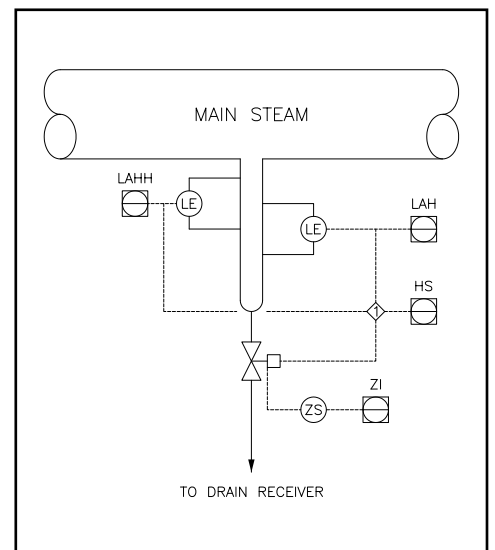
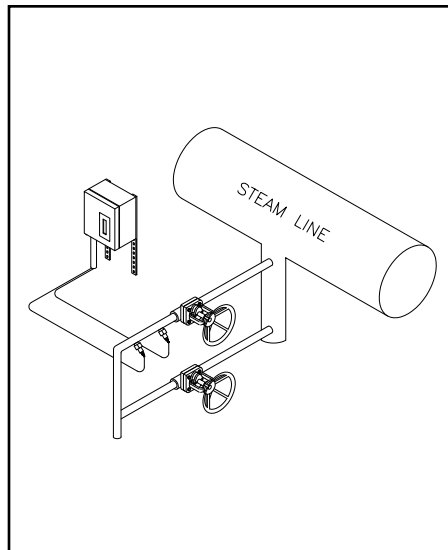
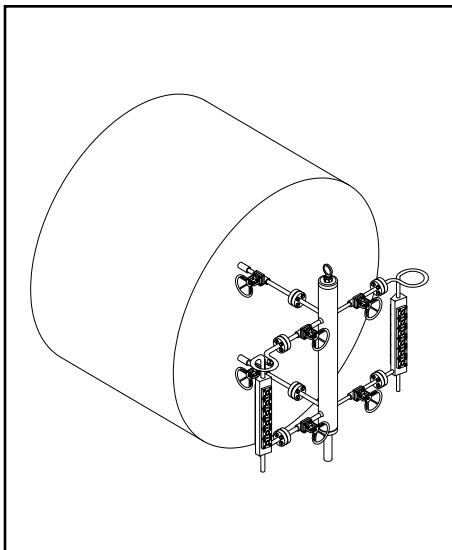

Water Level Measurement

The Principles Underlying the Product

Overview

Reliable detection of condensate levels within boiler drums is one of the most critical measurements required in a steam generation plant. Low condensate levels can damage boiler tubes while high condensate levels can damage steam turbines. These are catastrophic events that result in significant maintenance costs, but are fully preventable with the right safeguards.

Fortunately, steam and condensate have distinct electrical properties. Condensate is far more conductive (and less resistive) than steam. Boilers therefore produce a wide range of condensate conductivities within their drum and piping systems. These simple properties can be leveraged to provide accurate, reliable measurement of condensate levels through two different approaches: conductivity and resistivity. Quest-Tec offers both in our indirect gages.

Conductivity

The conductivity approach utilizes a series of switches to determine the drum's condensate level. A control unit houses detection modules that deliver a low voltage signal to probe tips in a water column. When a probe tip is submerged in condensate, its circuit is completed and two sets of DPDT

Resistivity

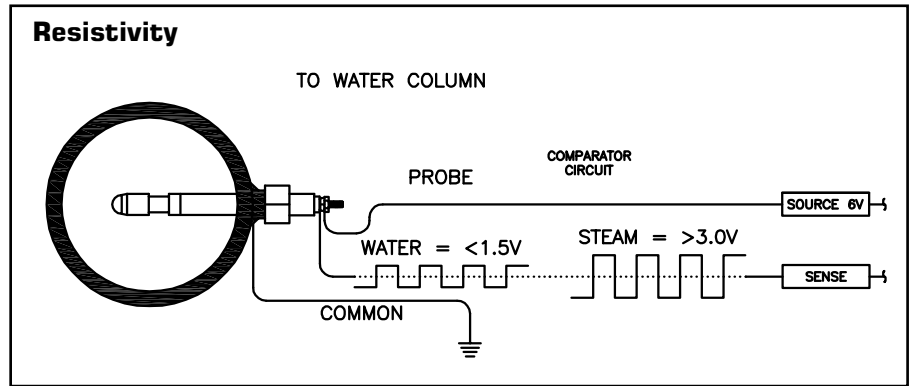

"Form C" Dry contacts change state. By reading the probes' switches and noting their locations, the condensate level is apparent.

The Level-Trac LT-100 Series is based on this principle and supports any number of horizontally or vertically mounted probes. The standard control units come in 50 k Ω sensitivity, but are also available in 25 or 75 k Ω . The 11 pin module plug in design is easily replaceable in the field by hand. An optional remote indicator may be mounted up to 500 ft away in a Fiberglass Reinforced Polycarbonate Nema-4X enclosure or control panel mount.

Resistivity

The resistivity approach is a more technically nuanced approach that measures electrical resistance to determine condensate levels.

Resistivity between condensate and steam is measured in a calibrated cell of the water column. The cell dimensions create a calibrated resistance typically greater than or equal to 0.1 M Ω when condensate is absent. When condensate is present, the resistance in the cell drops below 0.1 M Ω . A resistivity circuit is arranged to sense whether the probe resistance is less than or greater than the 0.1 M Ω mark within a series of cells to determine how many contain condensate. The condensate level in the drum becomes apparent in a manner similar to the conductivity system. The detection level is independent of water purity and boiler operating conditions.

The Level-Trac LT-210, 220, and 310 Series Electronics are based on this principles. As there is a continual live signal on every channel, this system offers engineered redundancy with fault tolerant fail safe operation. A push-to-test button completely tests the electronics integrity and system's operation, a feature that aids in troubleshooting.

Whether you prefer the operating principles of conductivity or resistivity, Quest-Tec Solutions can fulfill your water level measurement needs with quality products and service.

Conductivity

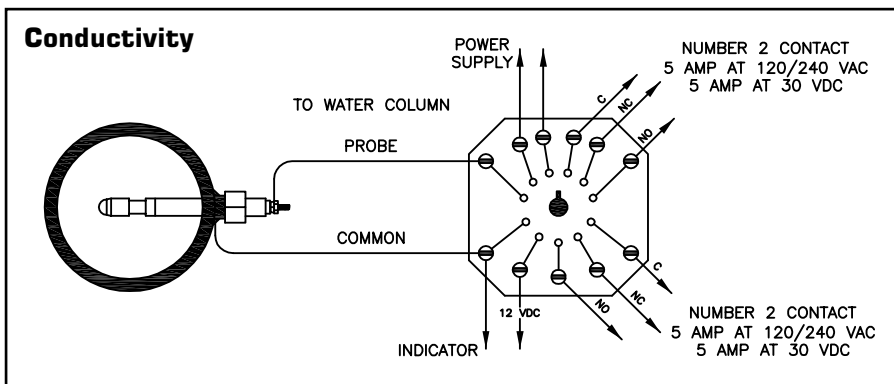

The following is an overview of Quest Tec Solution's standard steam products. For more in depth information, contact your Quest-Tec Sales Representative. You can also contact Quest-Tec directly by phone at 866-240-9906, by email at sales@qtslevel.com, or online at www.qtslevel.com.

Turbine

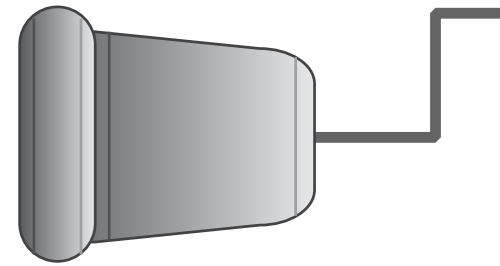

Direct Reading Gages

350

PSI



ST-350

Chamber: A-696 GR.C, Carbon Steel
 Gasket: Grafoil® GHR
 Glass: Tempered Borosilicate
 Cover: Forged Carbon Steel
 U-Bolts: A193-B7 Nickel Plated
 Nuts: A194-2H Nickel Plated
 Spring Washers: 17-7 PH SST Nickel Plated

The Quest-Tec Steam-Trac product line fully complies with the ASME Section I requirement for Direct Reading Gage Glass. Steam-Trac products are designed specifically for the rigorous service condition of steam generation, and consistently yield lower maintenance cost than competitive products.

450

PSI



ST-450

Chamber: A-696 Grade C Carbon Steel
 Gasket: Grafoil® GHR
 Shield: HQ Mica
 Glass: Tempered Borosilicate
 Cover: Forged Carbon Steel
 Studs: A193-B7 Nickel Plated
 Nuts: A194-2H Nickel Plated
 Spring Washers: 17-7 PH SST Nickel Plated

SLI-A See-Level Illuminator



for Steam Service
 Lighting: Amber LED's angled at 45° for easy viewing of meniscus
 Power Supply: 115/230 VAC @ 50/60 HZ
 Power Consumptions: <150 mA @ 115 VAC
 Supply Connection: 3/4 NPT
 Ambient Temperature: -40°F (-40°C) to 150°F (65°C)
 LED Estimated Life: 100,000 hours
 Certification: UL1203, UL913, CSA22.2, CL I, DIV 1, Groups B, C, & D, NEMA 4X & 8

1000

PSI



ST-1000

Chamber: A-105 Carbon Steel
 Gasket: Grafoil® GHR
 Shield: HQ Mica
 Glass: Tempered Borosilicate
 Cover: Forged Carbon Steel
 Studs: A193-B7 Nickel Plated
 Nuts: A194-2H Nickel Plated
 Spring Washers: 17-7 PH SST Nickel Plated

STBI-3000 Bi-Color Illuminator



Power Supply: 84-264 VAC
 Power Consumption: 0.24 Amps per 5 Ports
 Power Supply Enclosure: NEMA 4X, Anodized Aluminum
 Lighting: Long Life, Low Current, High Intensity LED Lamps
 Material: 304 Stainless Steel
 Connection Type: Quick Connect Latches for Ease of Assembly

1600

PSI



ST-1600

Chamber: A516 Grade 70 Carbon Steel
 Gasket: Grafoil® GHR
 Shield: HQ Mica
 Glass: Tempered Borosilicate
 Cover: A516 Carbon Steel
 Studs: A193-B7 Nickel Plated
 Nuts: A194-2H Nickel Plated
 Spring Washers: 17-7 PH SST Nickel Plated

Spare Parts

Kits including glass, gaskets, cushions and shields are available for repair of Quest-tec or OEM direct reading gages.

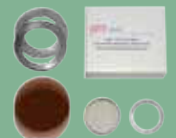

Gaskets, cushions, glass & shields for reflex and transparent style gages

Glass, Gaskets, Cushions, & Mica Shields for STB-3000 Bi-Color Ported Gage

3000

PSI



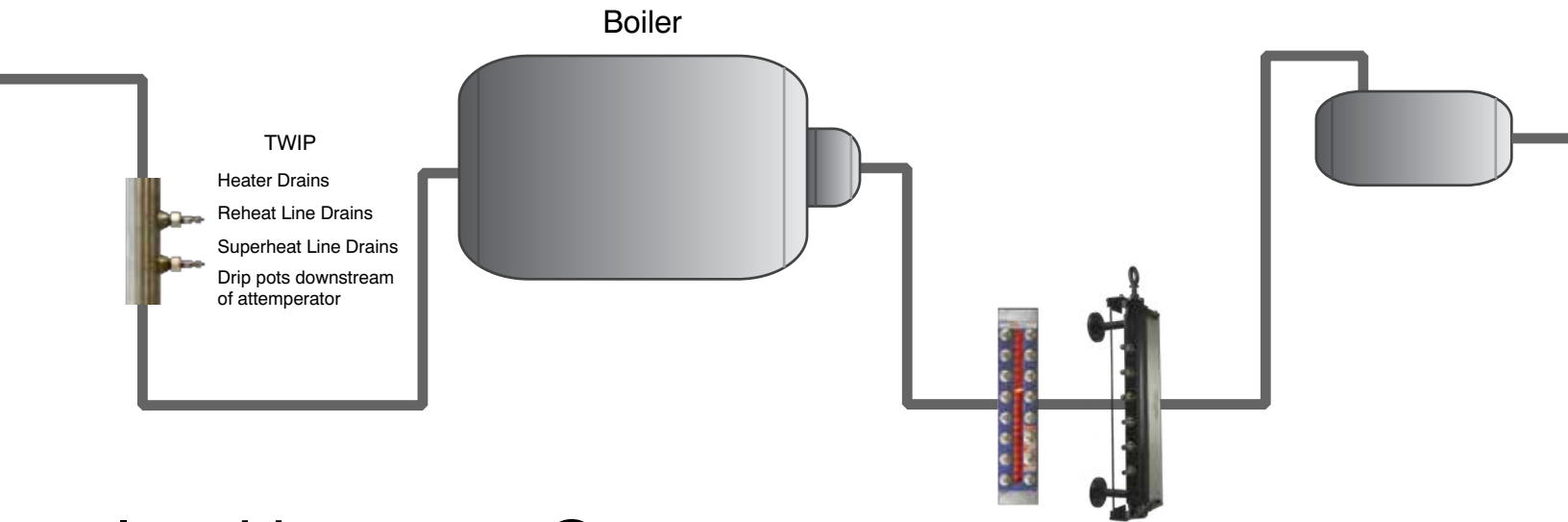

STB-3000

Chamber: 304 SS Single-piece Extruded
 Gasket: Spiral Wound Grafoil
 Shield: Ruby HQ Mica
 Glass: Tempered Aluminosilicate
 Cover: Carbon Steel
 Bolts: A193-B7 Nickel Plated
 Bi-color Illuminator Required



Indirect Gages

Quest-Tec Solutions Level-Trac products are designed exclusively to sense water in steam generation process. Level-Trac systems include remote water level indicators per ASME Section I and turbine water induction protection.

1000 PSI	<p>LT-500</p> <p>Chamber: A-105 Extruded Probe Mounting: Horizontal Probe Type: Type 800 Probe Gasket: Spiral Wound</p>	<p>Type 800</p> <p>Probe Rating: 1000 PSI WSP; 550 F Threaded Column Connection High Quality Spiral Wound Gasket TFE Insulator Ceramic to Metal Vacuum Brazing</p>
2000 PSI	<p>LT-501</p> <p>Chamber: A-105 Extruded Probe Mounting: Horizontal Probe Type: 801 Probe Gasket: Spiral Wound</p>	<p>Type 810</p> <p>Probe Rating: 2000 PSI WSP; 1100 F Threaded Column Connection Helium Leak Tested High Quality Spiral Wound Gasket Zirconium Insulator Ceramic to Metal Vacuum Brazing</p>
3000 PSI	<p>LT-502</p> <p>Chamber: A-106B Schedule 160 Probe Mounting: Horizontal Probe Type: 802 Probe Seal: Ferrule Seat</p>	<p>Type 820</p> <p>Probe Rating: 3000 PSI WSP; 1100 F Single Hex Nut Closure Helium Leak Tested Metal-to-metal Ferrule Seat Zirconium/Aluminosilicate Insulator Ceramic to Metal Vacuum Brazing</p>
1000 - 2000 PSI	<p>LT-40 / LT-41</p> <p>Point Level Switch Installation Within Any Vertical Pipe Run Top/Bottom End Connections 3/4" or 1", F.NPT or SW Chamber: A-106B Carbon Steel No. of Probes: 1-2 Rating: 1,000 PSI (LT-40) Rating: 2,000 PSI (LT-41) (Recommended Control Unit: LT-310)</p>	<p>OEM Probe Upgrade Kits</p> <p>Level-Trac probe upgrade kits offer a better value as compared to original equipment manufacturers. Probe upgrades are available for manufacturers such as:</p> <div style="display: flex; justify-content: space-around;"> <div style="text-align: center;">  Clark Reliance Yarway/Fossil </div> <div style="text-align: center;">  Diamond Power Hydrastep </div> </div>

Heaters

Deaerator

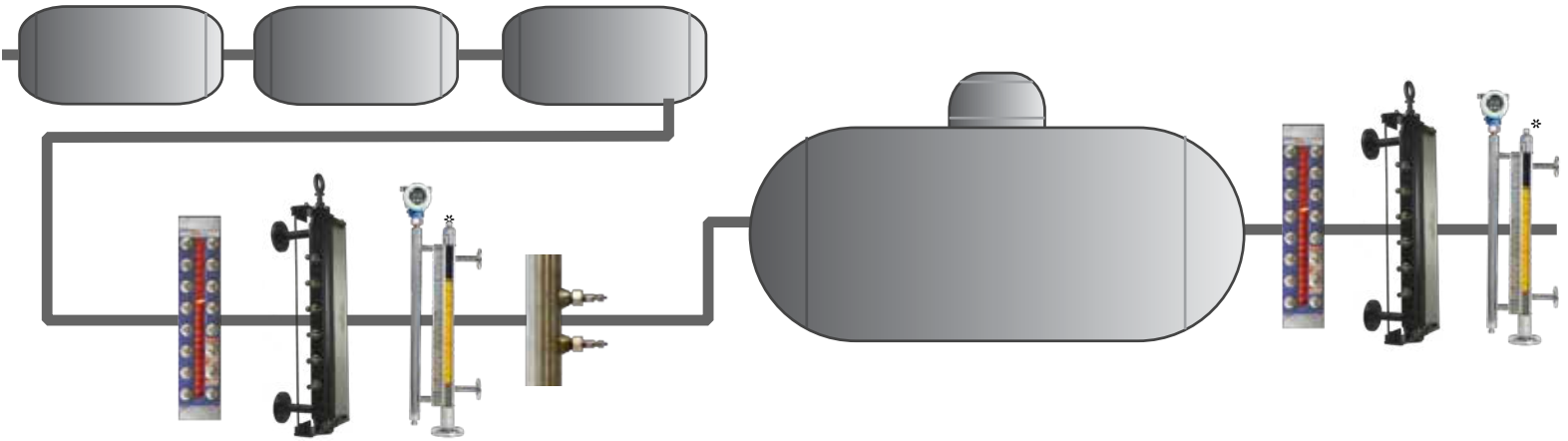

Electronic Control Units

LT-100 Series



Probe Channels: 1 - 12
 Relays: All Channels
 Power Supply: Single 120-240 VAC
 Enclosure: NEMA 4X Fiberglass Reinforced Polyester
 Features: Plug-In Detection Modules



LT-210



Probe Channels: 1 - 12
 Relays: 2 Alarms, 2 Validated Trips, 1 Fault, 8A DPDT
 Power Supply: Single 100-240 VAC
 Output Power: 4-20mA, Remote Display
 Enclosure: NEMA 4X Fiberglass Reinforced Polyester
 Features: Sequence Fault Detection
 Door mounted LED indicator



LT-220



Probe Channels: 1 - 14
 Relays: 2 Alarms, 2 Validated Trips, 1 Fault 8A DPDT
 Power Supply: Dual 100-240 VAC
 Output Power: 4-20mA, Remote Display
 Enclosure: NEMA 4X Fiberglass Reinforced Polyester
 Features: Sequence Fault Detection
 Door mounted LED indicator



LT-310



Probe Channels: 1 - 6
 Relays: Alarm/Trip Relays used individually or in validation, 6 8A DPDT
 Power Supply: Dual, 100-240 VAC
 Output Power: Remote Display
 Enclosure: NEMA 4X Fiberglass Reinforced Polyester
 Features: Door mounted LED indicator Solid State Circuitry



Remote Indicators



Each of these electronic units are available with remote indicators. These remote indicators come with individual channel wiring and the LT-210 and LT-220 models have an option for serial transmission.



High Temperature Cabling

Our cable is designed specifically for use with Level-Trac Remote Level Indicator Systems for connection of the probe column to the control unit. The probe side will be terminated with high temperature, nickel plated steel, un-insulated ring terminals for connection to the probes and common lug.

Custom Designed Level Measurement Products

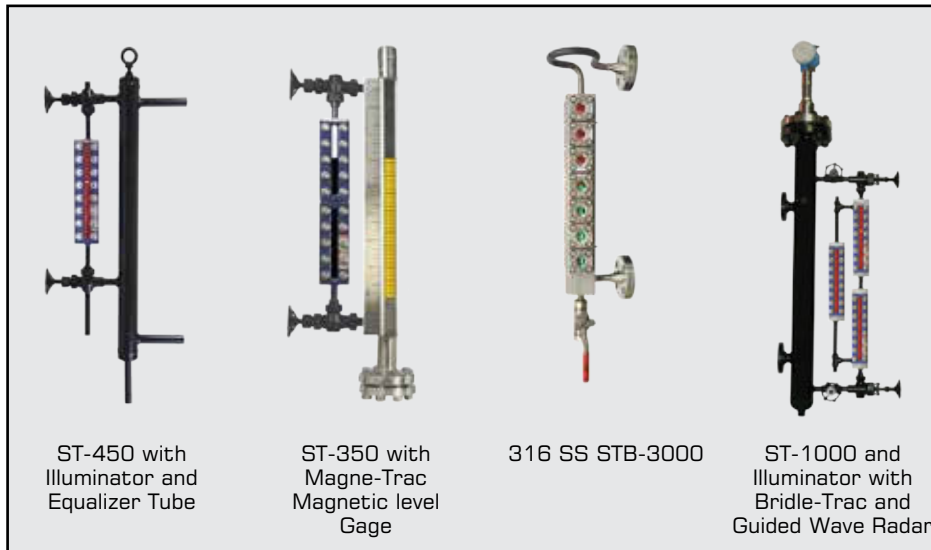

ST-450 with Illuminator and Equalizer Tube

ST-350 with Magne-Trac Magnetic level Gage

316 SS STB-3000

ST-1000 and Illuminator with Bridle-Trac and Guided Wave Radar

Valves

450

PSI

SV-450



Offset Pattern
Grafoil Packing for Temperatures to 700 F
Screwed Bonnet
Removable Seat
Eccentric Union Tank Connector
Optional Back-seating Stem

Quest-Tec Solutions steam valves are designed specifically for use with water level gages in steam/water service. The angled flow path compactly facilitates installation of the level gage, bringing the assembly connection point to the side. Each model is designed to prevent steam galling and maximize packing life to extend the longevity of the valve.

1100

PSI

SV-1100



Offset Pattern
Outside Screw & Yoke (OS&Y) Design
Non-Union Solid Shank Tank Connector
Bolted Bonnet
Grafoil Packing for Temperatures to 700 F
Non-rotating Back-seating Stem

Valve Options

Gasketed Union Gage Connection to allow rotation of viewing angle
Quick-Closing Levers
Chainwheel Operation
Vertical Rising Ball Check

1600

PSI

SV-1600



Offset Pattern
Outside Screw & Yoke (OS&Y) Design
Non-Union Solid Shank Tank Connector
Bolted Bonnet
Grafoil Packing for Temperatures to 700 F
Non-rotating Back-seating Stem

Gage Options

Isolation or Drain Valves per customer requirements
Gasketed Union Gage Connection to allow rotation of viewing angle
Stainless Steel Construction for Offshore or Corrosive Environments
Center Tie-Tube to Meet Any Visible Range

3000

PSI

SV-3000



Outside screw & yoke design
Back Seating Stem
Graphite packing
High performance packing system
Integral Gland Wrench
Clampseal Bonnet/Chamber

Column Options

Isolation or Drain Valves per customer requirements
Pre-wired, Integral Mounted Junction Box
Alternate Materials Available for Corrosive Environments and Extreme Temperatures

QUEST-TEC SOLUTIONS

Contact Quest-Tec

Phone:
866-240-9906

Email:
sales@qtslevel.com

Online:
www.qtslevel.com



Quest-Tec Solutions is a company focused on quality, identifying and matching customer needs with comprehensive and current product designs and features. The development and engineering of the liquid level gage and valve product lines began more than fifty years ago with Daniel Measurement & Control. Since then, we have expanded our product offering to include a complete line of magnetic level gauges and indicators, steam level gages and indicators and remote boiler drum level instrumentation and valves. Whether direct or indirect gages are required, we are a full line supplier for all your level needs.

The senior management of Quest-Tec is well respected within the industry for their leadership throughout the company's rapid growth. During the first seven years of operation, QTS received Houston Business Journal's "Fast 100 Growing Companies" award for two consecutive years. That growth led to the establishment of Quest-Tec's current site in Houston, Texas. The six acre site includes a state of the art 45,000 square foot manufacturing facility utilizing CNC machinery to produce products efficiently with consistently high quality.

In 2011, Quest-Tec Solutions received ISO 9001:2008 certification from the ANSI-ASQ National Accreditation Board. We are also now proud to offer products in compliance with PED. These certifications are a testament to the same high quality standards from which our customers have always benefited. As a leader in liquid level measurement innovation, we will continue to offer the quality and performance our customers expect.

Represented By:



Quest-tec Headquarters
Houston, TX



CNC Machining of
ST-1600 Cover